

Structure Silicon Monolithic Integrated Circuit  
 Product Name 4-Parallel white-LED Driver for mobile phone

Type **BD1604MVV**

Features Automatically transition to each mode (x1,x1.5,x2) charge pump type  
 DC/DC converter 4 channels LED Driver (Max 30mA × 4 = 120mA)

○Absolute Maximum Ratings (Ta=25°C)

Parameter	Symbol	Rating	Unit	Condition
Power supply voltage	VCC	7.0	V	
Power Dissipation	Pd	780 (*1)	mW	
Input voltage	VIN	GND-0.3 ~ VBAT+0.3	V	
Operating Temperature Range	Topr	-30 ~ +85	°C	
Storage Temperature Range	Tstr	-55 ~ +150	°C	

(\*1) This value is the measurement value that was mounted on the PCB by ROHM.  
 (70mm×70mm×1.6mm glass epoxy Board)  
 Temperature delecting: 6.24mW/deg from Ta>25deg

○Recommended operating conditions (Ta=-30°C~+85°C)

Parameter	Symbol	Rating			Unit	Condition
		Min.	Typ.	Max.		
Power supply voltage	VBAT	2.7	3.6	5.5	V	

This product isn't designed to protect itself against radioactive rays.

## ○Electrical Characteristics

(Unless otherwise noted, Ta = +25°C, VBAT=3.6V)

Parameter	Symbol	Spec			Unit	Condition
		Min.	Typ.	Max.		
Logic control terminal						
Low threshold voltage	VthL	-	-	0.4	V	EN,SEL0,SEL1,SEL2
High threshold voltage	VthH	1.4	-	-	V	EN,SEL0,SEL1,SEL2
High level Input current1	IinH1	-	18.3	30	μA	VBAT=EN =5.5V
High level Input current2	IinH2	-	0	1	μA	VBAT=SEL0=SEL1=SEL2= 5.5V
Low level Input current	IinL	-1	0	-	μA	EN, SET0, SET1, SEL2=0V
Input voltage range	Vin	2.7	3.6	5.5	V	
Quiescent Current	Iq	-	0.1	1	μA	EN=0V
Current Consumption1	Idd1	-	1.0	2.0	mA	x1.0 Mode, Iout = 0mA
Current Consumption2	Idd2	-	2.5	3.5	mA	X2.0 Mode, Iout = 0mA
LED maximum current	I <sub>LEDmax</sub>	-	-	30	mA	
LED current accuracy	I <sub>LED-diff</sub>	-	-	±5.0	%	I <sub>LED1-4</sub> = 10mA
LED current matching	I <sub>LED-match</sub>	-	-	±3.0	%	I <sub>LED1-4</sub> = 10mA *1)
LED control voltage	V <sub>LED</sub>	0.08	0.1	0.2	V	
ISET voltage	Iset	0.5	0.6	0.7	V	RSET = 24kΩ
Over voltage limit	Vol	4.55	5.0	5.45	V	
Oscillator frequency	f <sub>osc</sub>	0.8	1.0	1.2	MHz	
LED current limiter	I <sub>LEDOV</sub>	40	60	100	mA	
VBAT supply -> EN active time	T <sub>VBATON</sub>	1	-	-	msec	
EN stand-by -> VBAT OFF time	T <sub>VBATOFF</sub>	0	-	-	nsec	
Start up time	T <sub>s</sub>	-	0.5	1	msec	
High term of SELn *1	T <sub>high</sub>	1	-	-	msec	

 \*1) LED current matching =  $(I_{LEDmax} - I_{LEDmin}) / (I_{LEDmax} + I_{LEDmin}) * 100$ 

 I<sub>LEDmax</sub> : Maximum value of LED1-4 current

 I<sub>LEDmin</sub> : Minimum value of LED1-4 current

External dimensions

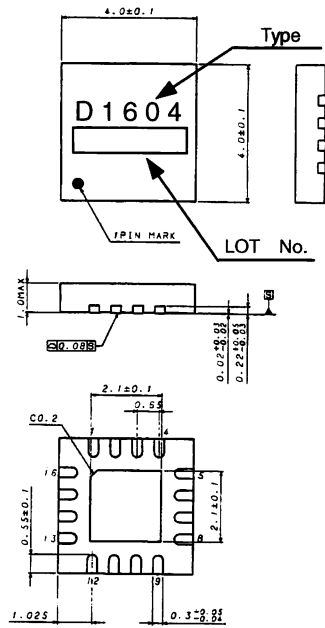

SQFN016V4040 (16PIN) (Unit : mm)

Terminals

PIN	Pin Name	PIN	Pin Name
1	EN	9	C1N
2	SEL0	10	C2N
3	SEL1	11	C2P
4	SEL2	12	GND
5	ISET	13	LED1
6	VOUT	14	LED2
7	VBAT	15	LED3
8	C1P	16	LED4

Block diagram

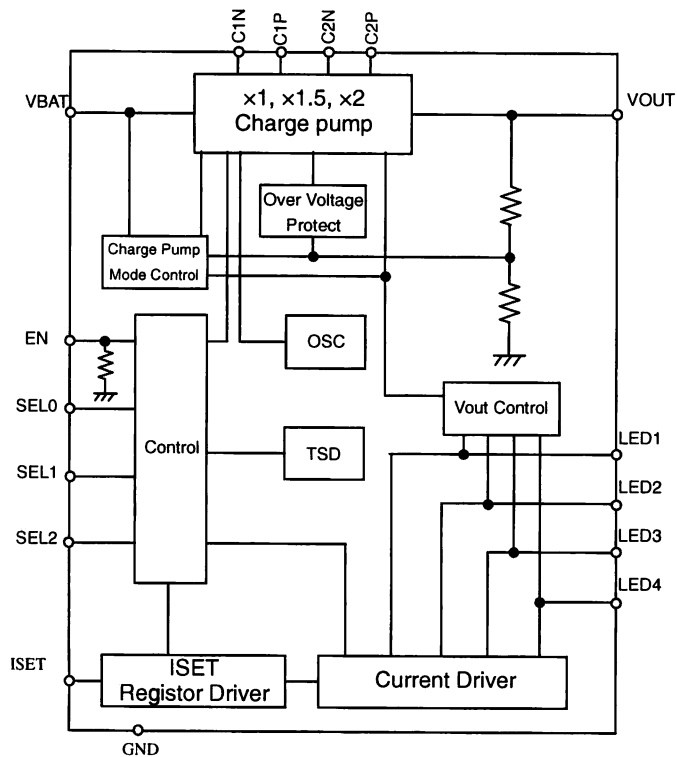

○Cautions on use

(1) Absolute Maximum Ratings

An excess in the absolute maximum ratings, such as supply voltage, temperature range of operating conditions, etc., can break down devices, thus making impossible to identify breaking mode such as a short circuit or an open circuit. If any special mode exceeding the absolute maximum ratings is assumed, consideration should be given to take physical safety measures including the use of fuses, etc.

(2) Power supply and GND line

Design PCB pattern to provide low impedance for the wiring between the power supply and the GND lines. Pay attention to the interference by common impedance of layout pattern when there are plural power supplies and GND lines. Especially, when there are GND pattern for small signal and GND pattern for large current included the external circuits, please separate each GND pattern. Furthermore, for all power supply terminals to ICs, mount a capacitor between the power supply and the GND terminal. At the same time, in order to use a capacitor, thoroughly check to be sure the characteristics of the capacitor to be used present no problem including the occurrence of capacity dropout at a low temperature, thus determining the constant.

(3) GND voltage

Make setting of the potential of the GND terminal so that it will be maintained at the minimum in any operating state. Furthermore, check to be sure no terminals are at a potential lower than the GND voltage including an actual electric transient.

(4) Short circuit between terminals and erroneous mounting

In order to mount ICs on a set PCB, pay thorough attention to the direction and offset of the ICs. Erroneous mounting can break down the ICs. Furthermore, if a short circuit occurs due to foreign matters entering between terminals or between the terminal and the power supply or the GND terminal, the ICs can break down.

(5) Operation in strong electromagnetic field

Be noted that using ICs in the strong electromagnetic field can malfunction them.

(6) Input terminals

In terms of the construction of IC, parasitic elements are inevitably formed in relation to potential. The operation of the parasitic element can cause interference with circuit operation, thus resulting in a malfunction and then breakdown of the input terminal. Therefore, pay thorough attention not to handle the input terminals, such as to apply to the input terminals a voltage lower than the GND respectively, so that any parasitic element will operate. Furthermore, do not apply a voltage to the input terminals when no power supply voltage is applied to the IC. In addition, even if the power supply voltage is applied, apply to the input terminals a voltage lower than the power supply voltage or within the guaranteed value of electrical characteristics.

(7) External capacitor

In order to use a ceramic capacitor as the external capacitor, determine the constant with consideration given to a degradation in the nominal capacitance due to DC bias and changes in the capacitance due to temperature, etc.

(8) Thermal shutdown circuit (TSD)

This LSI builds in a thermal shutdown (TSD) circuit. When junction temperatures become detection temperature or higher, the thermal shutdown circuit operates and turns a switch OFF. The thermal shutdown circuit, which is aimed at isolating the LSI from thermal runaway as much as possible, is not aimed at the protection or guarantee of the LSI. Therefore, do not continuously use the LSI with this circuit operating or use the LSI assuming its operation.

(9) Thermal design

Perform thermal design in which there are adequate margins by taking into account the permissible dissipation ( $P_d$ ) in actual states of use.

(10) Other cautions on use

Please consult supplementary documents such as technical notebook, function manual and application design guide of this LSI.