

2010

产品目录

ROHM
SEMICONDUCTOR

Discrete Semiconductors

Bipolar Transistors Digital Transistors

双极晶体管/数字晶体管



ROHM Co.,Ltd.

双极晶体管

产量名列世界前茅的ROHM晶体管以快速适应时代需求为目的，以节约能源、节省空间、高可靠性为开发理念，拥有满足市场需求的特色产品线。

数字晶体管

ROHM在世界范围内最先开发的数字晶体管，是活跃在数字电路设计领域中的电阻内置型晶体管。通过拓展适应市场需求的超小型封装，节省了空间，而且具备丰富的电阻值，产品线多种多样。

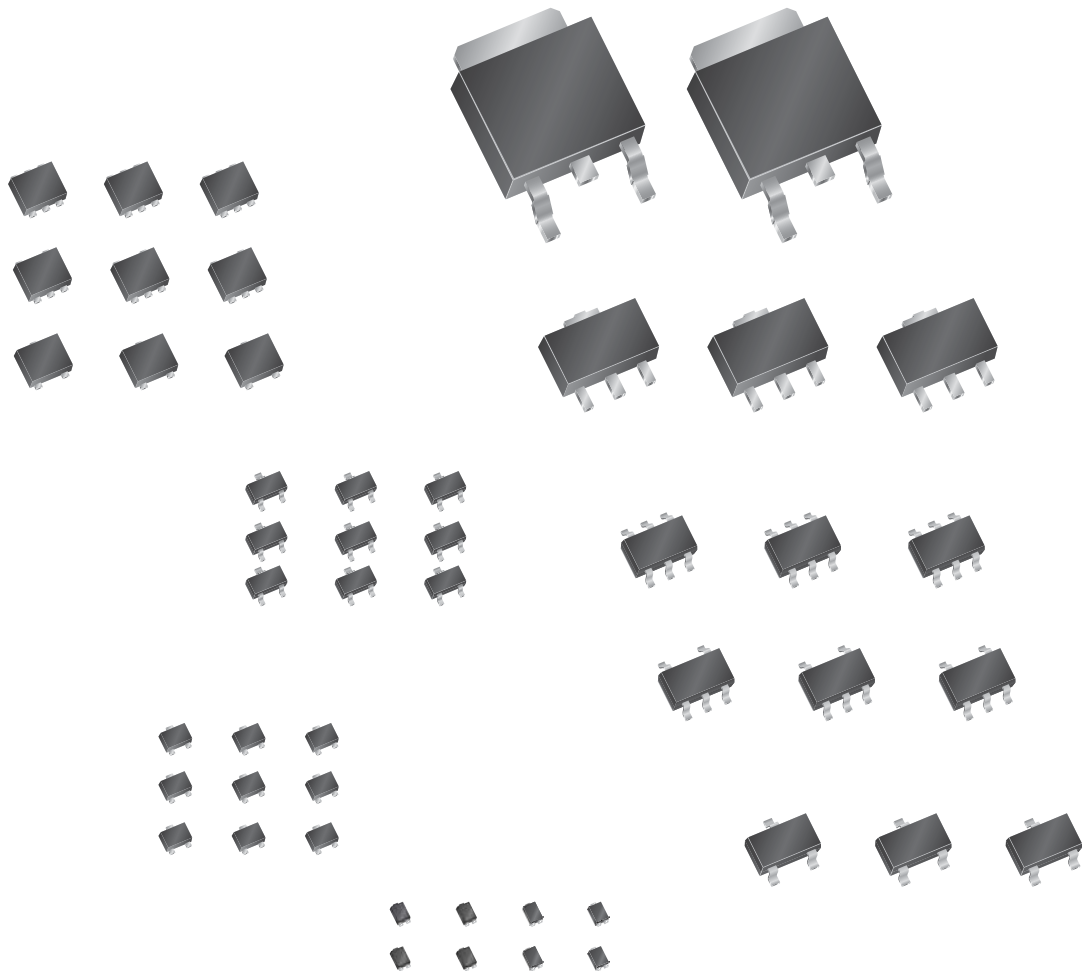

Contents

Close Up

超小型VMN3封装	3
VMT6小型复合封装	4
MPT6复合双极晶体管	5
螺线形电导管/马达驱动用晶体管	6
Low $V_{CE(sat)}$ 晶体管	7
MPT3高速开关晶体管	9
静音用晶体管	10

Lineup

双极晶体管	11	数字晶体管	17
复合双极晶体管	15	复合数字晶体管	18
外形尺寸图	19	品名构成说明	20

超小型 VMN3 封装

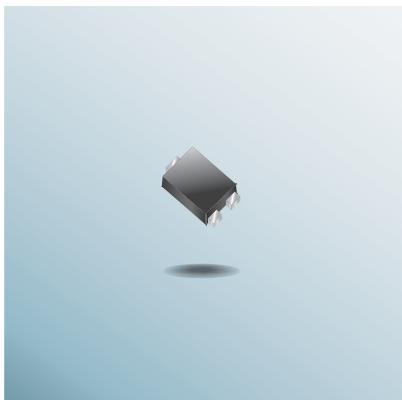

安装面积减少60%、高度降低35%

概要

相比以往VMT3封装产品，安装面积减少60%、高度降低35%，为超小型、薄型系列。

特点

- 超小型
- 薄型

用途

- 小型便携设备的通用开关 等

超小型、薄型

相比以往VMT3封装 (1.2×1.2, t=0.5mm)，安装面积减少60%、高度降低35%，为超小型、薄型封装 (0.6×1.0, t=0.37mm)。

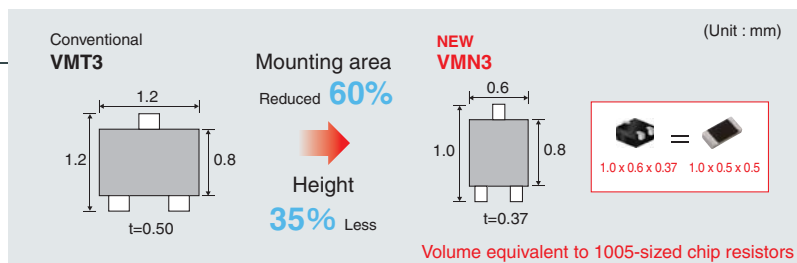

优秀的嵌条认知性、焊锡粘着强度

特点1

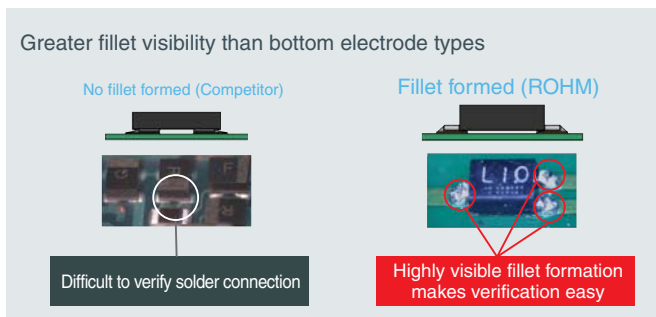

特点2

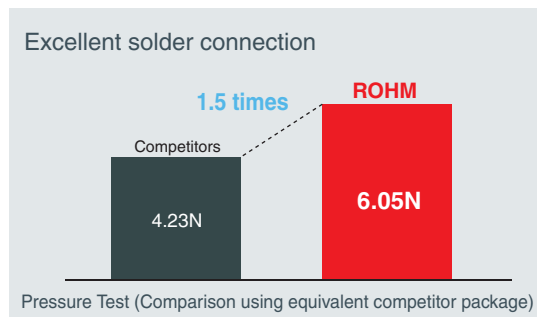

产品线

■ 双极晶体管

Part No.	Polarity	V _{CEO} (V)	I _c (mA)	h _{FE}		V _{CE(sat)} Max.	
				@ V _{CE} / I _c	(V)	@ I _c / I _B	
2SA2199	PNP	-50	-100	120 to 390	-6V / -2mA	-0.3	-25mA / -2.5mA
2SC6114	NPN	50	100	120 to 390	6V / 2mA	0.3	25mA / 2.5mA

■ 数字晶体管

Part No.	Polarity	V _{CC} (V)	I _o (mA)	R1 (KΩ)	R2 (KΩ)	GI
DTA114EB	PNP	-50	-50	10	10	30 or more
DTC114EB	NPN	50	50	10	10	30 or more
DTA144EB	PNP	-50	-50	47	47	68 or more
DTC144EB	NPN	50	50	47	47	68 or more

VMT6 小型复合封装



安装面积减少43%

概要

相比以往EMT6封装产品，安装面积减少43%。
而且，复合了以往产品VMT3，是将安装面积减少了50%的超小型复合封装。

特点

- 超小型
- 复合封装

用途

- 小型便携设备的通用开关
- 电流反射镜电路 等

超小型、复合化

相比以往EMT6封装(1.6×1.6, t=0.5mm)，安装面积减少43%。

而且，复合了以往产品VMT3封装(1.2×1.2, t=0.5mm)，是将安装面积减少了50%的超小型复合封装。

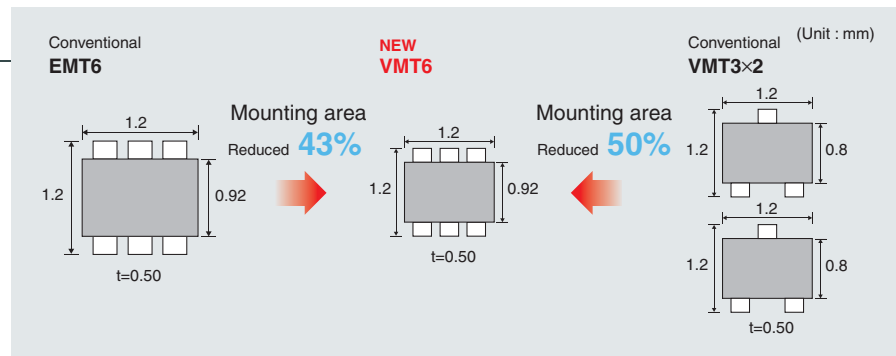

保证 hFE 的偶性

保证双电路的hFE偶性(hFE1/hFE2 0.9~1.1)
(VT6T11, VT6T12, VT6X11, VT6X12)

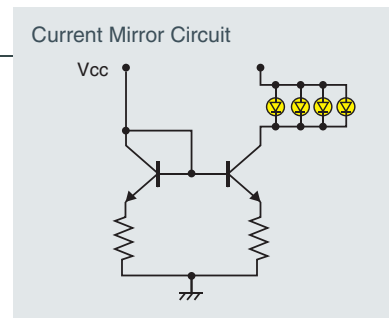

产品线

■ 双极晶体管

Part No.	V _{CEO} (V)	I _C (mA)	h _{FE}	h _{FE} Ratio	P _C (W)	Equivalent Circuit Diagram
New VT6T1	-20	-200				
New VT6T2	-50	-100				
New VT6X1	20	200				
New VT6X2	50	100				
New VT6T11	-20	-200	120 to 560	0.9 to 1.1	0.15	
New VT6T12	-50	-100				
New VT6X11	20	200				
New VT6X12	50	100				
New VT6Z1	-20 / 20	-200 / 200				
New VT6Z2	-50 / 50	-100 / 100				

MPT6复合双极晶体管

安装面积、部件数减半



概要

复合了以往的MPT3封装，安装面积减少50%，高度降低约35%，为小型，薄型系列。

特点

· 节省空间

用途

· 缓冲电路
· 集电极谐振电路
· 马达驱动电路

小型、薄型化封装

复合以往的MPT3封装，安装面积、部件数减半。例如，以往需要使用2个2SB1132产品，现在能够总括在1个“MPT6”封装内，从而有助于减少安装面积、削减安装成本。

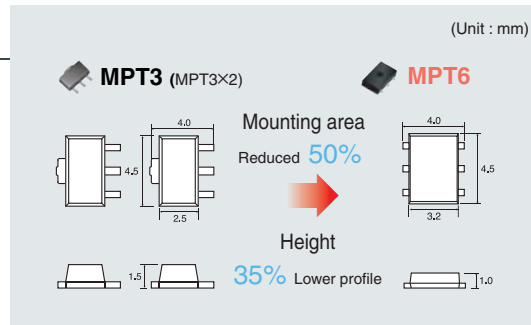

外形图

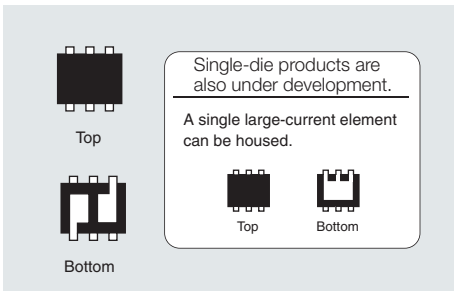

应用电路例

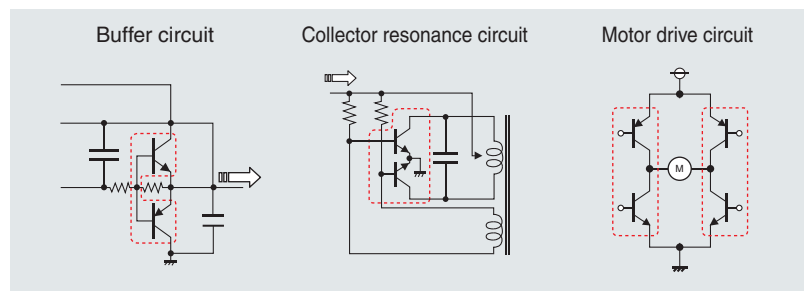

产品线

Part No.	Internal Circuit	Equivalent Element Transistors	V _{CEO} (V)	I _C (A)	h _{FE}
MP6T1		2SB1132×2	-32	-1	120 to 390
MP6T2		2SB1188×2	-32	-2	120 to 390
MP6T3		2SA2071×2	-60	-3	120 to 270
MP6X1		2SD1664×2	32	1	120 to 390
MP6X2		2SD1766×2	32	2	120 to 390
MP6X3		2SC5824×2	60	3	120 to 270
MP6Z1		2SB1132	-32	-1	120 to 390
MP6Z2		2SD1664	32	1	120 to 390
		2SB1188	-32	-2	120 to 390
MP6Z3		2SD1766	32	2	120 to 390
	2SA2071	-60	-3	120 to 270	
MP6H1		2SC5824	60	3	120 to 270
		DTDG14GP×2	60±10	1	300 or more

螺线形电导管/马达驱动用晶体管

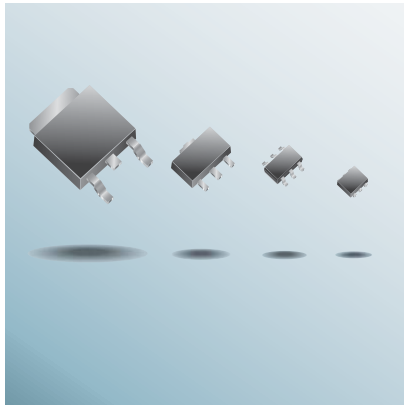

马达驱动电路的安装面积最大削减40%

概要

将马达驱动电路必需的箱位二极管、输入电阻、误动作防止电阻整合于单芯片中。相比安装单独部件的情况，面积可减少约40%。

特点

- 节省空间
- 耐损坏强度高
- 防止误动作

用途

- 马达驱动电路
- 继电器驱动电路
(车载设备、打印机等)

耐损坏强度高、节省空间

通过内部箱位二极管，吸收马达驱动时发生的反电动势。耐损坏强度高。并且，内置输入电阻和防止误动作电阻。马达驱动电路的安装面积最大可削减约40%。

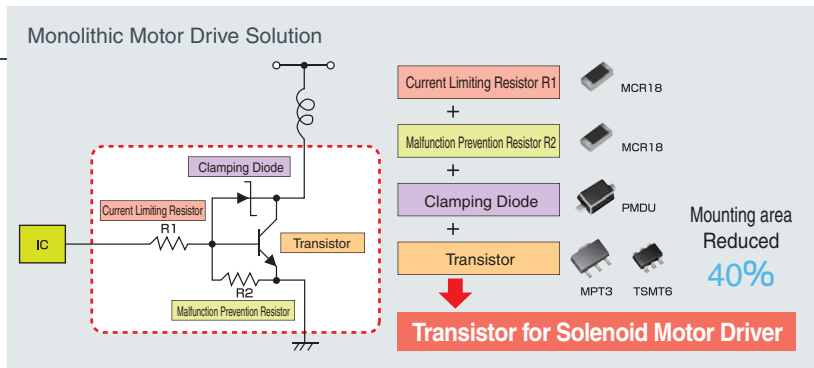

特性比较

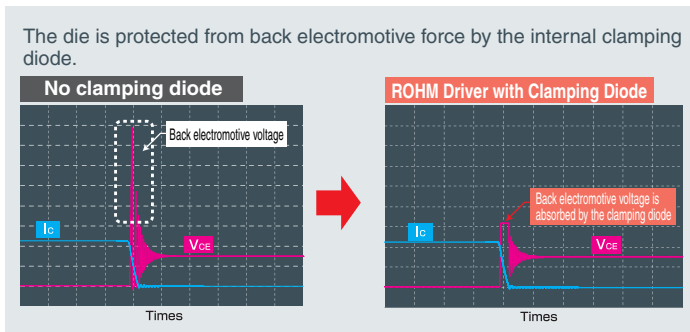

应用电路例

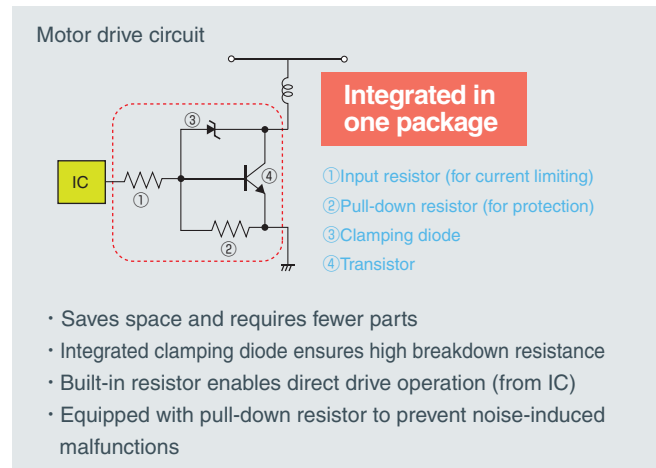

产品线

Package	Part No.	Internal Circuit	V _{CE0} (V _{CC}) (V)	I _C (I _O) (A)	h _{FE} (G)
MPT3 P _C =0.5W	DTDG23YP		60±10	1	300 or more
	DTDG14GP		60±10	1	300 or more
CPT3 (D-PAK) P _C =1W	2SD2143		60±10	2	1k to 10k
TSMT6 P _C =0.5W	QSH29		60±10	0.5	500 or more
MPT6 P _C =2W	MP6H1		60±10	1	300 or more

Low $V_{CE(sat)}$ 晶体管

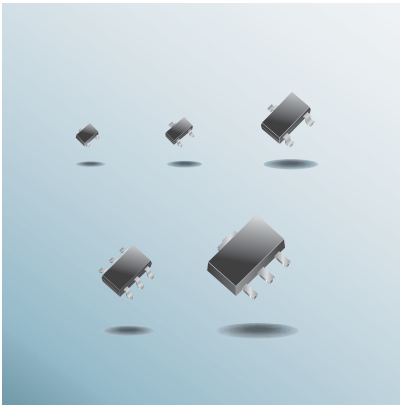

$V_{CE(sat)}$ 降低约80% 有助于节能

概要

拥有从VMT3至MPT3的表面安装封装。
最适合要求低功耗的便携设备和数字设备。

特点

· 低 $V_{CE(sat)}$

用途

· 通用开关
· DC/DC转换器 等

低 $V_{CE(sat)}$

相比以往产品，将 $V_{CE(sat)}$ 大幅度地减少约80%，有助于设备的节能化。并且，备有从VMT3到MPT3的丰富的产品线，集电极电流最大至6A。以小型便携设备为首，满足各种各样的应用需求。

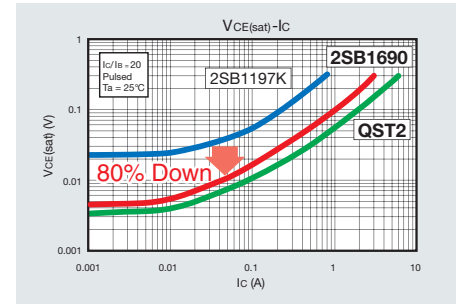
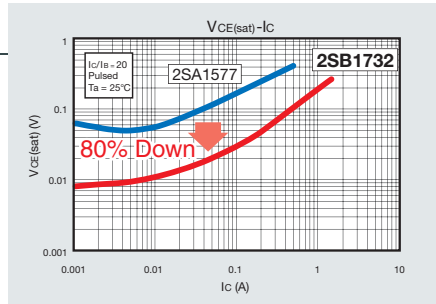

产品线

■ Single型 (表面安装型)

Package	VMT3		EMT3		UMT3		SMT3		V_{CE0} (V)	I_C (A)	h_{FE}^{*2}
	Polarity		Polarity		Polarity		Polarity				
Application	PNP NPN		PNP NPN		PNP NPN		PNP NPN				
Low $V_{CE(sat)}$	2SA2030	2SC5663	2SA2018	2SC5585	—	—	2SA2119K	—	12	0.5	270 to 680
	—	—	—	—	2SB1689	2SD2652	—	—	12	1.5	270 to 680
	—	—	—	—	—	—	2SB1690K	2SD2653K	12	2	270 to 680
	—	2SD2696	—	—	—	—	—	—	30	0.4	270 to 680
	—	—	—	—	2SB1694	2SD2656	—	—	30	1	270 to 680
—	—	—	—	—	—	2SB1695K	2SD2657K	30	1.5	270 to 680	

Package	TUMT3		TUMT6		TSMT3		TSMT6		MPT3		V_{CE0} (V)	I_C (A)	h_{FE}^{*2}
	Polarity		Polarity		Polarity		Polarity		Polarity				
Application	PNP NPN		PNP NPN		PNP NPN		PNP NPN		PNP NPN				
Low $V_{CE(sat)}$	2SB1732	2SD2702	—	—	2SB1709	2SD2674	—	—	—	—	12	1.5	270 to 680
	2SB1730	2SD2700	US6T6	US6X5	2SB1690	2SD2653	QST6	QSX5	2SB1697	2SD2661	12	2	270 to 680
	—	—	US6T4	US6X3	2SB1705	2SD2670	QST4	QSX3	2SB1713	2SD2678	12	3	270 to 680
	—	—	—	—	2SB1707	2SD2672	—	—	—	—	12	4	270 to 680
	—	—	—	—	—	—	QST2	QSX1	—	—	12	6	270 to 680
	2SB1733	2SD2703	—	—	2SB1710	2SD2675	—	—	—	—	30	1	270 to 680
	2SB1731	2SD2701	US6T7	US6X6	2SB1695	2SD2657	QST7	QSX6	2SB1698	2SD2662	30	1.5	270 to 680
	—	—	US6T5	US6X4	2SB1706	2SD2671	QST5	QSX4	2SB1714	2SD2679	30	2	270 to 680
	—	—	—	—	2SB1708	2SD2673	—	—	—	—	30	3	270 to 680
	—	—	—	—	—	—	QST3	QSX2	—	—	30	5	270 to 680

注) 1. *1 为安装于推荐焊盘时。
2. *2 关于 h_{FE} ，请参照规格书。
3. PNP型的 (-) 符号省略。

■ 复合型 (表面安装型)

Configuration	Package		EMT5 / EMT6	UMT5 / UMT6	SMT5 / SMT6	TUMT5 / TUMT6	TSMT5 / TSMT6	Equivalent Element Transistors	V _{CE0} (V)	I _c (mA)	h _{FE}
	Application	Equivalent Circuit Diagram (TOP View)	Part No.								
PNP×2	Preamp		EMT18	UMT18N	IMT18	—	—	2SA2018×2	-12	-500	270 to 680
	Driver		—	—	—	US6T8	QST8	2SB1709×2	-12	-1.5(A)	270 to 680
—			—	—	US6T9	QST9	2SB1710×2	-30	-1(A)	270 to 680	
NPN×2	Preamp		EMX18	UMX18N	—	—	—	2SC5585×2	12	500	270 to 680
			EMX28	—	—	—	—	2SD2696×2	30	400	270 to 680
	Driver		—	—	—	US6X7	QSX7	2SD2674×2	12	1.5(A)	270 to 680
			—	—	—	US6X8	QSX8	2SD2675×2	30	1(A)	270 to 680
PNP + NPN	Preamp		EMZ7	—	—	—	—	2SA2018 2SC5585	-12 12	-500 500	270 to 680 270 to 680
			EMZ8	—	—	—	—	2SA2018 2SC2412K	-12 50	-500 150	270 to 680 120 to 560
	DC/DC Converter		—	—	—	—	QSZ1	2SB1690 2SD2653	-12 12	-2(A) 2(A)	270 to 680 270 to 680
			—	—	—	—	QSZ2	2SB1695 2SD2657	-30 30	-1.5(A) 1.5(A)	270 to 680 270 to 680
			—	—	—	—	QSZ3	2SB1705 2SD2670	-12 12	-3(A) 3(A)	270 to 680 270 to 680
			—	—	—	—	QSZ4	2SB1706 2SD2671	-30 30	-2(A) 2(A)	270 to 680 270 to 680
PNP+Di	DC/DC Converter		EML4	UML4N	—	—	—	2SA2018 RB521S-30	-12 30	-500 200	270 to 680 —
			—	—	FML9	US5L9	QSL9	2SB1689 RB461F	-12 20	-1.5(A) 700	270 to 680 —
NPN+Di			EML6	UML6N	—	—	—	2SC5585 RB521S-30	12 30	500 200	270 to 680 —
			—	—	FML10	US5L10	QSL10	2SD2652 RB461F	12 20	1.5(A) 700	270 to 680 —
—	—	—	—	—	US5L12	QSL12	2SD2675 RB461F	30 20	1(A) 700	270 to 680 —	

EMT5/EMT6/UMT5/UMT6/TUMT5/TUMT6/TSMT5/TSMT6封装的等效电路图的右上为1pin, SMT5/SMT6封装的等效电路图的右下为1pin

MPT3 高速开关晶体管

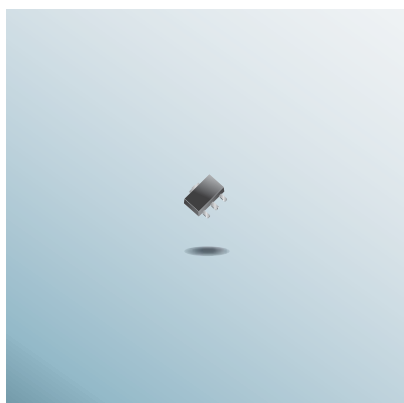

关闭速度提高约35% 有助于节能

概要

通过将元件结构最佳化，提高开关速度。

能够降低开关损失，控制发热量。

特点

· 高速开关

用途

· 缓冲电路
· 马达驱动电路
· 电源 等

高速开关

通过将关闭速度提高约35%，
降低开关损失，控制发热量。

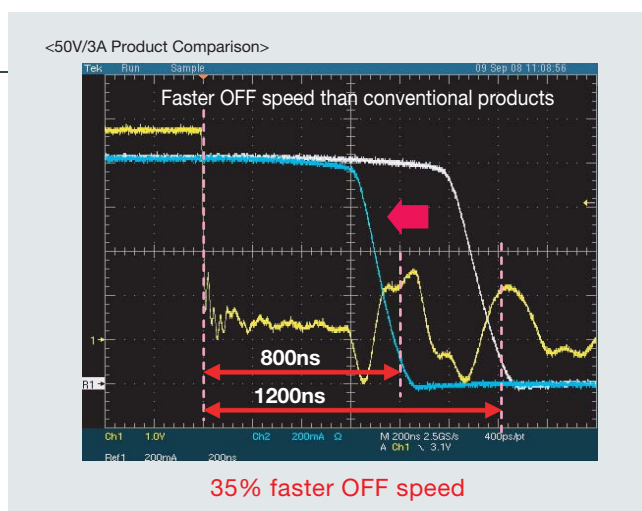

产品线

Part No.	Polarity	V _{CEO} (V)	I _c (A)	h _{FE}
2SAR512P	PNP	-30	-2	200 to 500
2SAR552P			-3	
2SAR542P		-50	-5	180 to 450
2SAR553P			-2	
2SAR533P		-3	120 to 390	
2SAR514P		-0.7		
2SAR554P		-1.5		
2SAR544P		-2.5		
2SCR512P	NPN	30	2	200 to 500
2SCR552P			3	
2SCR542P			5	
2SCR553P		50	2	180 to 450
2SCR533P			3	
2SCR514P		0.7	120 to 390	
2SCR554P		1.5		
2SCR544P		2.5		

静音用晶体管

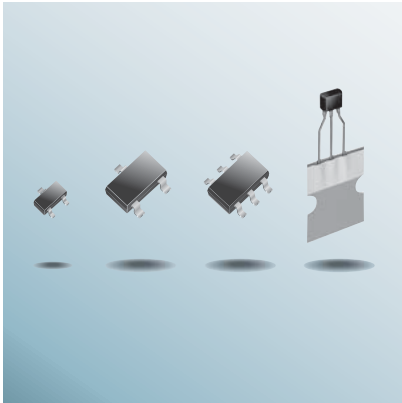

高 h_{FE} · 高 V_{EBO}

概要

凭借高 h_{FE} 且高 V_{EBO} ，最适合音响设备的静音电路。

特点

- 高 h_{FE}
- 高 V_{EBO}

用途

- 家用音响
- 汽车音响等
- 音响设备的静音电路

优秀的静音特性

高 h_{FE} 且高 V_{EBO} ($V_{EBO}=12V$ 以及 $25V$)元件中，新推出了 $40V$ 产品，具有出色的静音特性。产品线范围广泛，从小型表面安装的UMT3封装到插件型SPT封装，能够对应各种各样的音响设备。

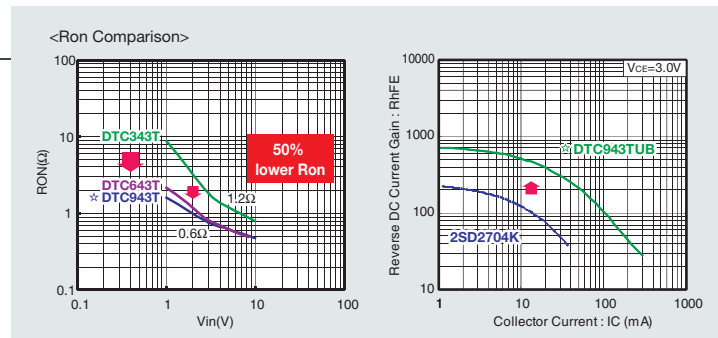

产品线

■ 电阻内置型

Part No.	R1 (kΩ)	Equivalent circuit diagram	Package				$V_{EBO}(V)$	$V_{CEO}(V)$	$I_c(mA)$	$R_{on}(\Omega)$
			UMT3F	UMT3	SMT3	SPT				
DTC623T	2.2		—	●	●	●	12	20	600	0.4
☆ DTC923T			●	—	—	—	40	20	400	0.6
DTC643T	4.7		—	●	●	●	12	20	600	0.55
☆ DTC943T			●	—	—	—	40	20	400	0.6
DTC614T			—	●	●	●	12	20	600	0.9
			—	—	—	—	—	—	—	—
□ : Packaging designation symbol			UB	U	K	S				

☆ : 开发中

■ 电阻内置型（复合品）

Part No.	R1 (kΩ)	Equivalent circuit diagram	Equivalent element transistors	Package			$V_{EBO}(V)$	$V_{CEO}(V)$	$I_c(mA)$	$R_{on}(\Omega)$	
				SMT6	TUMT6	UMT6					
☆ UMH33	2.2		☆ DTC923T	—	—	●	40	20	400	0.6	
☆ UMH32			☆ DTC943T	—	—	●	40	20	400	0.6	
US6H23	4.7		DTC643T	—	●	—	12	20	600	0.55	
IMH23			●	—	—	12	20	600	0.55		
IMH21			10	DTC614T	●	—	—	12	20	600	0.9
				—	—	—	—	—	—	—	—

☆ : 开发中

■ Single型

Package				$V_{EBO}(V)$	$V_{CEO}(V)$	$I_c(mA)$	h_{FE}	$R_{on}(\Omega)$
EMT3	UMT3	SMT3	SPT					
—	—	2SD2704K	2SD2705S	25	20	300	820 to 2700	0.7
2SD2654	2SD2351	2SD2226K	2SD2227S	12	50	150	820 to 2700	0.9
—	—	2SD2114K	2SD2144S	12	20	500	560 to 2700	0.8

■ 复合型

Package		Equivalent circuit diagram	Equivalent element transistors	$V_{EBO}(V)$	$V_{CEO}(V)$	$I_c(mA)$	h_{FE}	$R_{on}(\Omega)$
EMT6	SMT6							
—	IMX25		2SD2704K	25	20	300	820 ~ 2700	0.7
EMX26	—		2SD2654	12	50	150	820 ~ 2700	0.9
—	IMX9		2SD2114K	12	20	500	560 ~ 2700	0.8



双极晶体管

■ 表面安装型

Package	VMN3		VMT3		EMT3F		EMT3		V _{CEO} (V)	I _C (A)	h _{FE} *2
	Pc=0.15W		Pc=0.15W		Pc=0.15W		Pc=0.15W				
Polarity	PNP	NPN	PNP	NPN	PNP	NPN	PNP	NPN			
General Purpose Amplification	2SA2199	2SC6144	—	—	—	—	—	—	50	0.1	120 to 390
	—	—	2SA2029	2SC5658	2SA1774EB	2SC4617EB	2SA1774	2SC4617	50	0.15	120 to 390
	—	—	—	—	—	—	—	—	120	0.05	180 to 560
Low V _{CE(sat)}	—	—	2SA2030	2SC5663	—	—	2SA2018	2SC5585	12	0.5	270 to 680
	—	—	—	—	—	—	—	—	15	0.5	120 to 560
	—	—	—	—	—	—	—	—	15	1	120 to 270 180 to 390
	—	—	—	—	—	—	—	—	12	1.5	270 to 680
	—	—	—	—	—	—	—	—	12	2	270 to 680
	—	—	—	2SD2696	—	—	—	—	300	0.4	270 to 680
	—	—	—	—	—	—	—	—	30	1	270 to 680
	—	—	—	—	—	—	—	—	30	1.5	270 to 680
Driver	—	—	—	—	—	—	—	—	32	0.5	120 to 390
	—	—	—	—	—	—	—	—	32	0.8	120 to 390
	—	—	—	—	—	—	—	—	50	0.5	120 to 390
	—	—	—	—	—	—	—	—	80	0.5	120 to 390
High-speed Switching	—	—	—	—	—	—	—	—	60	0.5	120 to 270 120 to 390
High h _{FE} and Muting	—	—	—	—	—	—	—	—	25 (V _{EBO})	0.3	820 to 2700
	—	—	—	—	—	—	—	—	20	0.5	820 to 2700
	—	—	—	2SD2707	—	—	—	2SD2654	50	0.15	820 to 2700
High Breakdown Voltage	—	—	—	—	—	—	—	—	300	0.1	56 to 120
High Frequency	—	—	—	2SC5659	—	—	—	2SC4618	25	0.05	82 to 180 (f _T =300MHz)
	—	—	—	—	—	—	—	—	6	0.05	180 to 560 (f _T =800MHz)
	—	—	—	2SC5661	—	—	—	2SC4725	20	0.05	82 to 180 (f _T =1500MHz)
	—	—	—	2SC5662	—	—	—	2SC4726	11	0.05	56 to 180 (f _T =3200MHz)
Darlington*3	—	—	—	—	—	—	—	—	32	0.3	5k or more
	—	—	—	—	—	—	—	—	32 (V _{CES})	0.3	5k or more

- 注) 1. *1 为安装于推荐焊盘时。
 2. *2 关于h_{FE}, 请参照规格书。
 3. *3 关于内部电路, 请参照规格书。
 4. PNP型的(-)符号省略。

■ 表面安装型

Package	UMT3F		UMT3		SMT3		V _{CEO} (V)	I _C (A)	h _{FE} *2
	 P _C =0.2W*1		 P _C =0.2W*1		 P _C =0.2W*1				
Polarity	PNP	NPN	PNP	NPN	PNP	NPN			
Application	PNP	NPN	PNP	NPN	PNP	NPN			
General Purpose Amplification	—	—	—	—	—	—	50	0.1	120 to 390
	2SA1576UB	2SC4081UB	2SA1576A	2SC4081	2SA1037AK	2SC2412K	50	0.15	120 to 390
	—	—	2SA1579	2SC4102	2SA1514K	2SC3906K	120	0.05	180 to 560
Low V _{CE(sat)}	—	—	—	—	2SA2119K	—	12	0.5	270 to 680
	—	—	—	—	—	2SD1757K	15	0.5	120 to 560
	—	—	—	—	2SB1590K	2SD2444K	15	1	120 to 270/ 180 to 390
	—	—	2SB1689	2SD2652	—	—	12	1.5	270 to 680
	—	—	—	—	2SB1690K	2SD2653K	12	2	270 to 680
	—	—	—	—	—	—	30	0.4	270 to 680
	—	—	2SB1694	2SD2656	—	—	30	1	270 to 680
Driver	—	—	2SA1577	2SC4097	2SA1036K	2SC2411K	32	0.5	120 to 390
	—	—	—	—	2SB1197K	2SD1781K	32	0.8	120 to 390
	—	—	—	2SD1949	—	2SD1484K	50	0.5	120 to 390
	—	—	—	—	2SB1198K	2SD1782K	80	0.5	120 to 390
High-speed Switching	—	—	2SA2088	2SC5876	—	—	60	0.5	120 to 270/ 120 to 390
High h _{FE} and Muting	—	—	—	—	—	2SD2704K	25 (V _{EBO})	0.3	820 to 2700
	—	—	—	—	—	2SD2114K	20	0.5	820 to 2700
	—	—	—	2SD2351	—	2SD2226K	50	0.15	820 to 2700
High Breakdown Voltage	—	—	—	—	—	2SC4061K	300	0.1	56 to 120
High Frequency	—	—	—	2SC4098	—	2SC2413K	25	0.05	82 to 180 (f _T =300MHz)
	—	—	—	2SC4774	—	2SC4713K	6	0.05	180 to 560 (f _T =800MHz)
	—	—	—	2SC4082	—	2SC3837K	20	0.05	82 to 180 (f _T =1500MHz)
	—	—	—	2SC4083	—	2SC3838K	11	0.05	56 to 180 (f _T =3200MHz)
Darlington*3	—	—	—	—	—	2SD2142K	30	0.3	5k or more
	—	—	—	—	2SB852K	2SD1383K	32 (V _{CES})	0.3	5k or more





注) 1. *1 为安装于推荐焊盘时。



2. *2 关于h_{FE}, 请参照规格书。

3. *3 关于内部电路, 请参照规格书。

4. PNP型的(-)符号省略。

■ 表面安装型





Package	TUMT3		TUMT6		TSMT3		TSMT6		V _{CEO} (V)	I _C (A)	h _{FE} *2
	 Pc=0.4W*1		 Pc=0.4W*1		 Pc=0.5W*1		 Pc=0.5W*1				
Application	PNP	NPN	PNP	NPN	PNP	NPN	PNP	NPN			
Low V _{CE} (sat)	2SB1732	2SD2702	—	—	2SB1709	2SD2674	—	—	12	1.5	270 to 680
	2SB1730	2SD2700	US6T6	US6X5	2SB1690	2SD2653	QST6	QSX5	12	2	270 to 680
	—	—	US6T4	US6X3	2SB1705	2SD2670	QST4	QSX3	12	3	270 to 680
	—	—	—	—	2SB1707	2SD2672	—	—	12	4	270 to 680
	—	—	—	—	—	—	QST2	QSX1	12	6	270 to 680
	2SB1733	2SD2703	—	—	2SB1710	2SD2675	—	—	30	1	270 to 680
	2SB1731	2SD2701	US6T7	US6X6	2SB1695	2SD2657	QST7	QSX6	30	1.5	270 to 680
	—	—	US6T5	US6X4	2SB1706	2SD2671	QST5	QSX4	30	2	270 to 680
Driver	—	—	—	—	☆2SAR543R	☆2SCR543R	—	—	50	3.5	180 to 450
	—	—	—	—	New 2SAR544R	New 2SCR544R	—	—	80	2.5	120 to 390
High-speed Switching	—	—	—	—	2SA2090	2SC5868	—	—	60	0.5	120 to 270/ 120 to 390
	—	—	—	—	2SA2092	2SC5865	—	—	60	1	120 to 270/ 120 to 390
—	—	—	—	2SA2094	2SC5866	—	—	60	2	120 to 270/ 120 to 390	

Package	MPT3		CPT3		V _{CEO} (V)	I _C (A)	h _{FE} *2
	 Pc=0.5W*1		 Pc=1W*1				
Application	PNP	NPN	PNP	NPN			
Low V _{CE} (sat)	2SB1697	2SD2661	—	—	12	2	270 to 680
	2SB1713	2SD2678	—	—	12	3	270 to 680
	2SB1424	2SD2150	—	—	20	3	180 to 390/ 120 to 390
	—	—	2SB1412	2SD2118	20	5	120 to 390
	—	—	2SA1834	2SC5001	20	10	180 to 390/ 120 to 390
	2SB1698	2SD2662	—	—	30	1.5	270 to 680
2SB1714	2SD2679	—	—	30	2	270 to 680	
Driver	New 2SAR512P	New 2SCR512P	—	—	30	2	200 to 500
	New 2SAR552P	New 2SCR552P	—	—	30	3	200 to 500
	New 2SAR542P	New 2SCR542P	—	—	30	5	200 to 500
	2SB1132	2SD1664	—	—	32	1	120 to 390
	2SB1188	2SD1766	2SB1182	2SD1758	32	2	120 to 390
	☆2SAR513P	☆2SCR513P	—	—	50	1	180 to 450
	New 2SAR553P	New 2SCR553P	—	—	50	2	180 to 450
	New 2SAR533P	New 2SCR533P	—	—	50	3	180 to 450
	—	—	2SB1184	2SD1760	50	3	120 to 390
	2SB1561	2SD2391	—	—	60	2	120 to 270
	—	—	2SA1952	2SC5103	60	5	120 to 270
	New 2SAR514P	New 2SCR514P	—	—	80	0.7	120 to 390
	2SB1260	2SD1898	2SB1181	2SD1733	80	1	120 to 390
New 2SAR554P	New 2SCR554P	—	—	80	1.5	120 to 390	
New 2SAR544P	New 2SCR544P	—	—	80	2.5	120 to 390	
—	—	2SB1275	2SD1918	160	1.5	82 to 180/ 120 to 270	
High-speed Switching	2SA2071	2SC5824	2SA2072	2SC5825	60	3	120 to 270/ 120 to 390
High h _{FE}	—	2SD2537	—	—	25	1.2	820 to 1800
	2SB1427	—	—	—	20	2	390 to 820
	—	2SD2153	—	—	25	2	820 to 1800
	—	—	—	2SD2318	60	3	560 to 1800
Darlington*3	—	2SD1834	—	—	60 (V _{GES})	1	2k or more
	—	—	—	2SD2143	60±10	2	1k to 10k
—	—	2SB1316	2SD1980	100	2	1k to 10k	

注) 1. *1 为安装于推荐焊盘时。
 2. *2 关于h_{FE}，请参照规格书。
 3. *3 关于内部电路，请参照规格书。
 4. PNP型的(-)符号省略。

☆：开发中

■ 插件型

Package	SPT		ATV		V_{CE0} (V)	I_C (A)	h_{FE}^{*3}
							
Polarity	$P_C=0.3W$ ^{*1}		$P_C=1W$ ^{*2}				
Application	PNP	NPN	PNP	NPN			
General Purpose Amplification	2SA1038S	2SC2389S	—	—	120	0.05	180 to 560
Low $V_{CE(sat)}$	—	2SD1468S ^{*5}	—	—	15	1	120 to 390
	—	2SD2687S ^{*5}	—	—	12	5	350 to 680
	2SA1585S ^{*5}	2SC4115S ^{*5}	—	—	20	2	120 to 390
Driver	2SA854S	2SC1741S	—	—	32	0.5	120 to 390
	2SA1515S	—	2SB1237	2SD1858	32	1	120 to 390
	—	—	2SB1240	2SD1862	32	2	120 to 390
	—	2SC1741AS	—	—	50	0.5	120 to 390
	—	—	2SB1443	—	50	3	120 to 270
	—	—	2SB1243	2SD1864	50	3	120 to 390
	—	—	2SB1238	2SD1859	80	0.7	120 to 390
	—	2SD1768S	2SB1241	2SD1863	80	1	120 to 390
	—	—	2SB1236	2SD1857	120	1.5 / 2	120 to 390
—	—	2SB1236A	2SD1857A	160	1.5	100 to 200	
High-speed Switching	—	—	2SA2093	2SC5880	60	2	120 to 270/ 120 to 390
	—	—	2SA2073	2SC5826	60	3	120 to 270/ 120 to 390
High h_{FE} and Muting	—	2SD2705S	—	—	25 (V_{EBO})	0.3	820 to 2700
	—	2SD2144S	—	—	20	0.5	820 to 2700
	—	2SD2227S	—	—	50	0.15	820 to 2700
High Breakdown Voltage	—	2SC3415S	—	2SC4015	300	0.1	56 to 120
High Frequency	—	2SC2058S	—	—	25	0.05	82 to 180 ($f_T=300MHz$)
Darlington ^{*4}	—	—	—	2SD1866	60±10	2	1k to 10k
	—	—	—	2SC5060	90±10	1	1k to 2.5k
	—	—	—	2SD1867	100	2	1k to 10k

注) 1. *1 为安装于推荐焊盘时。

2. *2 为安装于集电极铜焊盘面积1cm²以上、1.7mm厚的基板上时。

3. *3 关于 h_{FE} ，请参照规格书。

4. *4 关于内部电路，请参照规格书。

5. *5 $P_C=0.4$ (W)

6. PNP型的 (-) 符号省略。

复合双极晶体管

■ 表面安装型

Configuration	Package	Item	Equivalent circuit diagram (TOP View)	VT6	EMT5 / EMT6	UMT5 / UMT6	SMT5 / SMT6	TUMT5 / TUMT6	TSMT5 / TSMT6	MPT6	Equivalent transistors	V _{CEO} (V)	I _C (mA)	h _{FE}		
PNP×2	Preamp			—	EMT1	UMT1N	IMT1A	—	—	—	2SA1037AK×2	-50	-150	120 or more		
				—	—	—	IMT17	—	—	—	2SA1036K×2	-50	-500	120 to 390		
				—	EMT18	UMT18N	IMT18	—	—	—	2SA2018×2	-12	-500	270 to 680		
				—	—	—	—	—	—	MP6T1	2SB1132×2	-32	-1(A)	120 to 390		
				—	—	—	—	—	—	MP6T2	2SB1188×2	-32	-2(A)	120 to 390		
				—	—	—	—	—	—	MP6T3	2SA2071×2	-60	-3(A)	120 to 270		
	Driver			—	—	—	—	—	—	—	—	—	-20	-200	120 to 560	
				—	—	—	—	—	—	—	—	—	—	-50	-100	120 to 560
				—	EMT2	UMT2N	IMT2A	—	—	—	2SA1037AK×2	-50	-150	120 to 560		
				—	EMT3	—	IMT3A	—	—	—	2SA1037AK×2	-50	-150	120 to 560		
				—	—	—	IMT4	—	—	—	2SA1514K×2	-120	-50	180 or more		
				—	—	—	—	—	US6T8	—	2SB1709×2	-12	-1.5(A)	270 to 680		
Ideal for Current Mirrors			—	—	—	—	—	—	—	—	—	-30	-1(A)	270 to 680		
			—	—	—	—	—	—	—	—	—	—	-20	-200	120 to 560	
NPN×2	Preamp			—	EMX1	UMX1N	IMX1	—	—	—	2SC2412K×2	50	150	120 or more		
				—	EMX26	—	—	—	—	—	2SD2654×2	50	150	820 to 2700		
				—	EMX18	UMX18N	—	—	—	—	2SC5585×2	12	500	270 to 680		
				—	—	—	IMX9	—	—	—	2SD2114K×2	20	500	560 to 2700		
				—	—	—	IMX25	—	—	—	2SD2704K×2	20	300	820 to 2700		
				—	EMX28	—	—	—	—	—	2SD2696×2	30	400	270 to 680		
	Ideal for Current Mirrors			—	—	—	IMX17	—	—	—	2SD1484K×2	50	500	120 to 390		
				—	—	—	—	—	—	—	—	—	—	—	—	
				—	—	—	—	—	—	—	MP6X1	2SD1664×2	32	1(A)	120 to 390	
				—	—	—	—	—	—	—	MP6X2	2SD1766×2	32	2(A)	120 to 390	
				—	—	—	—	—	—	—	MP6X3	2SC5824×2	60	3(A)	120 to 390	
				—	—	—	—	—	—	—	—	—	—	—	20	200
Preamp			—	—	—	—	—	—	—	—	—	50	100	120 to 560		
			—	—	—	—	—	—	—	—	—	—	20	200	120 to 560	
High Frequency			—	EMX2	UMX2N	IMX2	—	—	—	2SC2412K×2	50	150	120 to 560			
			—	EMX3	UMX3N	IMX3	—	—	—	2SC2412K×2	50	150	120 to 560			
Driver			—	—	—	IMX8	—	—	—	2SC3906K×2	120	50	180 or more			
			—	—	UMX21N	—	—	—	—	2SC4713K×2	6	50	180 to 560			
Ideal for Current Mirrors			—	EMX4	UMX4N	IMX4	—	—	—	2SC3837K×2	20	50	56 to 180			
			—	EMX5	UMX5N	IMX5	—	—	—	2SC3838K×2	11	50	56 to 120			
PNP + NPN	Amplifier			—	—	—	—	—	—	—	—	—	—	—		
				—	EMY1	UMY1N	FMY1A	—	—	—	2SA1037AK	-50	-150	120 or more		
	Inverter Driver			—	—	—	FMY4A	—	—	—	—	—	—	—		
				—	—	—	—	—	—	—	—	—	—	—	—	
	Preamp			—	EMZ1	UMZ1	IMZ1A	—	—	—	—	—	—	—	—	
				—	EMZ7	—	—	—	—	—	—	—	—	—	—	—
				—	—	—	IMZ4	—	—	—	—	—	—	—	—	—
				—	—	—	—	—	—	—	—	—	—	—	—	—
				—	—	—	—	—	—	—	—	—	—	—	—	—
				—	—	—	—	—	—	—	—	—	—	—	—	—
	DC/DC Converter			—	—	—	—	—	—	—	—	—	—	—	—	
				—	—	—	—	—	—	—	—	—	—	—	—	—
—				—	—	—	—	—	—	—	—	—	—	—	—	
—				—	—	—	—	—	—	—	—	—	—	—	—	
—				—	—	—	—	—	—	—	—	—	—	—	—	
—				—	—	—	—	—	—	—	—	—	—	—	—	

EMT5/EMT6/UMT5/UMT6/TUMT5/TUMT6/TSMT5/TSMT6/MPT6封装的等效电路图右上为1pin, SMT5/SMT6封装的等效电路图右下为1pin

■ 表面安装型

Configuration	Package	Application	Item	Equivalent circuit diagram (TOP View)	EMT5 / EMT6	UMT5 / UMT6	SMT5 / SMT6	TUMT5 / TUMT6	TSMT5 / TSMT6	Equivalent transistors	V _{CE0} (V)	I _c (mA)	h _{FE}
					Part No.								
PNP+DTR	Power Management				EMF5	UMF5N	—	—	—	2SA2018 DTC144E	-12 50	-500 100	270 to 680 68 or more
				—	UMF28N	—	—	—	2SA1774 DTC124X	-50 50	-150 100	180 to 390 68 or more	
PNP + N-ch MOS					EMF6	UMF6N	—	—	—	2SA2018 2SK3019	-12 30	-500 100	270 to 680 —
PNP-DTR + N-ch MOS					EMF32	UMF32N	—	—	—	DTA143T 2SK3019	-50 30	-100 100	100 to 600 —
					EMF33	—	—	—	—	DTB513Z 2SK3019	-12 30	-500 100	140 or more —
NPN+DTR					EMF8	UMF8N	—	—	—	2SC5585 DTC144E	12 50	500 100	270 to 680 60 or more
NPN + N-ch MOS		EMF9	UMF9N	—	—	—	2SC5585 2SK3019	12 30	500 100	270 to 680 —			
PNP+Di	DC/DC Converter				—	UML1N	—	—	—	2SA1774 DAN202K	-50 80	-150 100	120 or more —
					—	UML4N	—	—	—	2SA2018 RB521S-30	-12 30	-500 200	270 to 680 —
					—	—	FML9	US5L9	QSL9	2SB1689 RB461F	-12 20	-1.5(A) 700	270 to 680 —
					—	—	—	—	QSL11	2SB1710 RB461F	-30 20	-1(A) 700	270 to 680 —
PNP-DTR + Di					EML17	—	—	—	—	DTA144E RB520G-30	-50 30	-100 100	68 or more —
NPN+Di					—	UML2N	—	—	—	2SC4617 DAN202K	50 80	150 100	120 or more —
		—	UML6N	—	—	—	2SC5585 RB521S-30	12 30	500 200	270 to 680 —			
		—	—	FML10	US5L10	QSL10	2SD2652 RB461F	12 20	1.5(A) 700	270 to 680 —			
		—	—	—	US5L12	QSL12	2SD2675 RB461F	30 20	1(A) 700	270 to 680 —			
NPN-DTR + Di		EML20	—	—	—	—	DTC123J RB521S-30	50 30	100 100	80 or more —			
NPN+Di	Shunt Regulator		New	New	—	—	—	2SC2412K VDZ6.8B	50 Vz=6.8	150 Iz=5	120 to 270 —		

EMT5/EMT6/UMT5/UMT6/TUMT5/TUMT6/TSMT5/TSMT6/MPT6封装的等效电路图右上为1pin, SMT5/SMT6封装的等效电路图右下为1pin

数字晶体管

■ 表面安装型

Specifications	Item	Part No.		R1 (kΩ)	R2 (kΩ)	Package								V _{CC} (V _{CE0}) (V)	I _o (I _c) (mA)	G _I (h _{FE})
		PNP	NPN			VMN3	VMT3	EMT3F	EMT3	UMT3F	UMT3	SMT3	MPT3			
		Type	Pd=150mW			Pd=200mW			Pd=500mW							
R1 = R2 Potential Divider Type	100mA	DTA123E□A	DTC123E□A	2.2	2.2	—	●	—	●	—	●	●	—	50	100	20 or more
		DTA143E□A	DTC143E□A	4.7	4.7	—	●	—	●	—	●	●	—	50	100	20 or more
		DTA114E□A	DTC114E□A	10	10	●	●	●	●	●	●	●	—	50	50	30 or more
		DTA124E□A	DTC124E□A	22	22	—	●	●	●	●	●	●	—	50	30	56 or more
		DTA144E□A	DTC144E□A	47	47	●	●	—	●	●	●	●	—	50	30	68 or more
		DTA115E□A	DTC115E□A	100	100	—	●	—	●	—	●	●	—	50	20	82 or more
	200mA	DTB743E□	DTD743E□	4.7	4.7	—	●	—	●	—	—	—	—	30	200	120 or more
		DTB543E□	DTD543E□	4.7	4.7	—	●	—	●	—	—	—	—	12	500	120 or more
		DTB113E□	DTD113E□	1	1	—	—	—	—	—	●	—	—	50	500	33 or more
		DTB123E□	DTD123E□	2.2	2.2	—	—	—	—	—	●	—	—	50	500	39 or more
		DTB143E□	DTD143E□	4.7	4.7	—	—	—	—	—	●	—	—	50	500	47 or more
		DTB114E□	DTD114E□	10	10	—	—	—	—	—	—	●	—	50	500	56 or more
R1 ≠ R2 Leak Absorption Type	100mA	DTA113Z□A	DTC113Z□A	1	10	—	—	—	DTA only	—	●	●	—	50	100	33 or more
		DTA123Y□A	DTC123Y□A	2.2	10	—	—	—	●	—	●	●	—	50	100	33 or more
		DTA123J□A	DTC123J□A	2.2	47	—	●	●	●	●	●	●	—	50	100	80 or more
		DTA143X□A	DTC143X□A	4.7	10	—	●	●	●	●	●	●	—	50	100	30 or more
		DTA143Z□A	DTC143Z□A	4.7	47	—	●	●	●	●	●	●	—	50	100	80 or more
		DTA114W□A	DTC114W□A	10	4.7	—	—	—	●	—	●	●	—	50	100	24 or more
		DTA114Y□A	DTC114Y□A	10	47	—	●	●	●	●	●	●	—	50	70	68 or more
		DTA124X□A	DTC124X□A	22	47	—	●	—	●	—	●	●	—	50	50	68 or more
		DTA144V□A	DTC144V□A	47	10	—	—	—	—	—	DTC only	●	—	50	100	33 or more
		DTA144W□A	DTC144W□A	47	22	—	—	—	—	—	●	●	—	50	30	56 or more
	200mA	DTB713Z□	DTD713Z□	1	10	—	●	—	●	—	—	—	—	30	200	140 or more
		DTB723Y□	DTD723Y□	2.2	10	—	●	—	●	—	—	—	—	30	200	140 or more
		DTB743X□	DTD743X□	4.7	10	—	●	—	●	—	—	—	—	30	200	140 or more
		DTB743Z□	DTD743Z□	4.7	47	—	●	—	●	—	—	—	—	30	200	150 or more
		DTB513Z□	DTD513Z□	1	10	—	—	—	—	—	—	—	—	12	500	140 or more
		DTB523Y□	DTD523Y□	2.2	10	—	●	—	●	—	—	—	—	12	500	140 or more
	500mA	DTB543X□	DTD543X□	4.7	10	—	●	—	●	—	—	—	—	12	500	140 or more
		DTB543Z□	DTD543Z□	4.7	47	—	●	—	●	—	—	—	—	12	500	150 or more
		DTB113Z□	DTD113Z□	1	10	—	—	—	—	—	—	●	—	50	500	56 or more
		DTB123Y□	DTD123Y□	2.2	10	—	—	—	—	—	—	●	—	50	500	56 or more
DTB143X□		DTD143X□	4.7	10	—	—	—	—	—	—	●	—	50	500	56 or more	
DTB143Z□		DTD143Z□	4.7	47	—	—	—	—	—	—	●	—	50	500	56 or more	
Type using R1 alone as Input Resistor	100mA	DTA113TKA	—	1	—	—	—	—	—	—	—	●	—	50	100	100 to 600
		—	DTC123TKA	2.2	—	—	—	—	—	—	—	●	—	50	100	100 to 600
		DTA143T□A	DTC143T□A	4.7	—	—	—	●	●	●	●	●	—	50	100	100 to 600
		DTA114T□A	DTC114T□A	10	—	—	—	●	●	●	●	●	—	50	100	100 to 600
		DTA124T□A	DTC124T□A	22	—	—	—	●	—	●	●	●	—	50	100	100 to 600
		DTA144T□A	DTC144T□A	47	—	—	—	●	—	●	●	●	—	50	100	100 to 600
	500mA	DTA115T□A	DTC115T□A	100	—	—	—	●	—	●	●	●	—	50	100	100 to 600
		DTA125T□A	DTC125T□A	200	—	—	—	—	—	●	●	●	—	50	100	100 to 600
		DTB123TK	DTD123TK	2.2	—	—	—	—	—	—	—	●	—	40	500	100 to 600
		DTB143TK	DTD143TK	4.7	—	—	—	—	—	—	—	●	—	40	500	100 to 600
For Muting	DTB114TK	—	10	—	—	—	—	—	—	—	●	—	40	500	100 to 600	
	—	DTC614T□	10	—	—	—	—	—	—	●	●	—	20	600	820 to 2700	
Type using R2 alone as Bleeder Resistor	100mA	DTA114G□A	DTC114G□A	—	10	—	—	—	—	—	●	●	—	50	100	30 or more
		DTA124G□A	DTC124G□A	—	22	—	—	—	—	—	DTC only	●	—	50	100	68 or more
		DTA144G□A	DTC144G□A	—	47	—	—	—	DTC only	—	●	●	—	50	100	68 or more
		DTA115G□A	DTC115G□A	—	100	—	—	—	—	—	●	●	—	50	100	68 or more
	500mA	DTB114GK	DTD114GK	—	10	—	—	—	—	—	—	●	—	—	500	56 or more
		—	DTDG14GP*1	—	10	—	—	—	—	—	—	—	●	60±10	1(A)	300 or more

□ : Package designations symbol

- *1 关于内部电路, 请参照规格书。
- VMN3、VMT3、EMT3F、EMT3、UMT3F的末尾不加A。
- PNP型的(-)符号省略。

复合数字晶体管

■ 表面安装型

Configuration	Package	Item	EMT5 / 6	UMT5 / 6	SMT5 / 6	TUMT5 / 6	TSMT6	MPT6	Equivalent transistors
			Part No.						
PNP × 2	Potential Divider Type		—	UMA1N	FMA1A	—	—	—	DTA124EX2
			EMA2	UMA2N	FMA2A	—	—	—	DTA144EX2
	Leak Absorption Type		—	UMA9N	FMA9A	—	—	—	DTA114EX2
			EMA5	UMA5N	FMA5A	—	—	—	DTA123JX2
	Input Resistor Type		EMA3	UMA3N	FMA3A	—	—	—	DTA143TX2
			EMA4	UMA4N	FMA4A	—	—	—	DTA114TX2
	Potential Divider Type		EMB2	UMB2N	IMB2A	—	—	—	DTA144EX2
		EMB11	UMB11N	IMB11A	—	—	—	DTA114EX2	
Potential Divider Type		EMB10	UMB10N	IMB10A	—	—	—	DTA123JX2	
Potential Divider Type		EMB6	UMB6N	—	—	—	—	DTA144EX2	
Input Resistor Type		EMB3	UMB3N	IMB3A	—	—	—	DTA143TX2	
NPN × 2	Potential Divider Type		EMG1	UMG1N	FMG1A	—	—	—	DTC124EX2
			EMG2	UMG2N	FMG2A	—	—	—	DTC144EX2
	Input Resistor Type		EMG9	UMG9N	FMG9A	—	—	—	DTC114EX2
			EMG3	UMG3N	FMG3A	—	—	—	DTC143TX2
	Potential Divider Type		EMG4	UMG4N	FMG4A	—	—	—	DTC114TX2
			EMG6	UMG6N	FMG6A	—	—	—	DTC144TX2
	Potential Divider Type		EMH1	UMH1N	IMH1A	—	—	—	DTC124EX2
			EMH2	UMH2N	IMH2A	—	—	—	DTC144EX2
	Leak Absorption Type		EMH11	UMH11N	IMH11A	—	—	—	DTC114EX2
			EMH9	UMH9N	IMH9A	—	—	—	DTC114YX2
	Potential Divider Type		—	UMH5N	IMH 5A	—	—	—	DTC124EX2
			EMH6	UMH6N	IMH6A	—	—	—	DTC144EX2
	Input Resistor Type		EMH3	UMH3N	IMH3A	—	—	—	DTC143TX2
			EMH4	UMH4N	IMH4A	—	—	—	DTC114TX2
		EMH15	—	IMH15A	—	—	—	DTC144TX2	
		—	—	IMH21	—	—	—	DTC614TX2	
Driver		—	—	—	—	—	—	DTC643TX2	
		—	UMH8N	IMH8A	—	—	—	DTC114TX2	
		—	UMH14N	IMH14A	—	—	—	DTC144TX2	
		—	—	—	—	—	—	DTC144TX2	
PNP + NPN	Potential Divider Type		EMD2	UMD2N	IMD2A	—	—	—	DTA124E
			EMD3	UMD3N	IMD3A	—	—	—	DTC124E
			EMD4	UMD4N	—	—	—	—	DTA114E
	Leak Absorption Type		EMD12	UMD12N	—	—	—	—	DTC114E
			EMD5	UMD5N	—	—	—	—	DTA114Y
			EMD9	UMD9N	IMD9A	—	—	—	DTC144E
	Input Resistor Type		EMD22	UMD22N	—	—	—	—	DTA143X
			EMD38	—	—	—	—	—	DTC144E
	Power Management		EMD6	UMD6N	IMD6A	—	—	—	DTA114Y
			EMD29	—	—	—	—	—	DTC114Y
			EMD30	—	—	—	—	—	DTA143Z
		—	—	IMD10A	—	—	—	DTC143Z	
		—	—	IMD16A	—	—	—	DTA113Z	
								DTC114Y	

EMT5/EMT6/UMT5/UMT6/TUMT5/TUMT6/TSMT5/TSMT6/MPT6封装的等效电路图右上为1pin, SMT5/SMT6封装的等效电路图右下为1pin

外形尺寸图

VMN3 	VMT3 	VMT6 	EMT3F 	EMT3 (SC-75A) (SOT-416) 	EMT5 	EMT6
UMT3F 	UMT3 (SC-70) (SOT-323) 	UMT5 (SC-88A) (SOT-353) 	UMT6 (SC-88) (SOT-363) 	SST3 (SOT-23) 		
SMT3 (SC-59) (SOT-346) 	SMT5 (SC-74A) 	SMT6 (SC-74) (SOT-457) 	TSST8 			
TUMT3 	TUMT5 	TUMT6 	WEMT6 			
TSMT3 	TSMT5 	TSMT6 	TSMT8 			
MPT3 (SC-62) (SOT-89) 	MPT6 	SOP8 				
CPT3 (SC-63) (SOT-428) 	TCPT3 	LPTS 	LPTL 			
SPT (SC-72) 	ATV 	TO-220FN 	TO-220FM 	TO-3PF 		

注) 1.封装代码下方()内字符为JEITA编号, < >内字符为JEDEC编号。
2.详细尺寸请参照规格书。

MEMO

MEMO

本资料所记载的内容是截至2009年10月1日的材料。

严厉禁止在没有得到罗姆公司许可的情况下下载、翻印本资料的部分或全部内容。

本资料所记载的内容，有基于为使其更加完善等原因而未先预告便进行修改的情况。

本资料所记载的内容只是产品的情况介绍。要使用该产品时，请务必通过别的途径获取规格说明书，进一步确认产品的规格及其性能。

关于本资料所记载的应用电路实例和它的参数等信息是说明本产品在规定动作和使用方法的条件下。所以在量产设计时请充分地考虑外部诸条件。

本资料所记载的内容是力求准确无误而慎重编制成的，但万一用户方出现因该内容存在错误或打字差错造成损失的情况，罗姆公司不予承担责任。

本资料所介绍的技术内容是产品的典型工作状况和应用电路举例等，对于罗姆或其他公司的知识产权及其他所有权利未做明确的、暗示的准予实施或使用的承诺。如因使用这些技术内容而引发纠纷，罗姆公司不予承担责任。

本资料所介绍的产品可应用于一般的电子设备（如AV装置、OA装置、通信设备、家用电器产品及娱乐设备，等等）。

本资料所述产品未作“防辐射设计”。

罗姆公司一直在努力提高产品的质量和可靠性，但有时还会出现这样那样的原因引发的故障。

希望所使用机器的减载、冗余设计、防火势蔓延、故障无碍等安全保障措施能够发挥作用，在罗姆产品出现故障时不至于产生人身安全事故、火灾损失等。如果超额使用或违反说明书上的使用注意事项，罗姆公司概不承担任何责任。

本产品不是为应用于要求有极高可靠性的、一旦该产品出现故障或误动作即会直接危及人命或损害人体的机器、装置和系统（如医疗器械、运输机器、航空宇航装置、原子能控制、燃料控制及各种安全装置，等等）而设计、制造的。如果应用于上面所列特定用途，罗姆概不承担任何责任。在考虑将本产品应用于上面所列特定用途时，请事先与罗姆的营业部门取得联系，共同讨论研究。

在输出本资料所介绍的产品及技术中符合「外国汇兑及外国贸易法」的产品或技术时，或者向国外提供时，必需取得依照该法发放的许可。

ROHM Sales Offices 如需详细信息，请联系我们。

大连	+86-411-8230-8549	无锡	+86-510-8270-2693	<亚洲>		<美洲>	
北京	+86-10-8525-2483	东莞	+86-769-8393-3320	新加坡	+65-6332-2322	圣地亚哥	+1-858-625-3630
深圳	+86-755-8307-3008	福州	+86-591-8801-8698	菲律宾	+63-2-807-6872	亚特兰大	+1-770-754-5972
上海	+86-21-6279-2727	广州	+86-20-3878-8100	泰国	+66-2-254-4890	达拉斯	+1-972-437-3748
杭州	+86-571-8765-8072	惠州	+86-752-205-1054	马来西亚	+60-3-7958-8355	<日本>	
南京	+86-25-8689-0015	厦门	+86-592-238-5705	韩国	+82-2-8182-700	京都	+81-75-365-1216
宁波	+86-574-8765-4201	珠海	+86-756-3232-480	<欧洲>		横滨	+81-45-476-2290
青岛	+86-532-8577-9312	香港	+852-2-740-6262	德国	+49-2154-9210		
苏州	+86-512-6807-1300	台北	+886-2-2500-6956	法国	+33-1-5697-3060		
天津	+86-22-2302-9181	高雄	+886-7-237-0881	英国	+44-1-908-272400		

R0039A

ROHM Co.,Ltd.

21 Saiin Mizosaki-cho, Ukyo-ku,
Kyoto 615-8585 Japan
TEL : +81-75-311-2121 FAX : +81-75-315-0172

ROHM
SEMICONDUCTOR

www.rohm.com.cn