



ML22Q284

ADPCM Speech Synthesis LSI for Automotive

■ GENERAL DESCRIPTION

ML22Q284 is a speech synthesis LSI supporting an in-vehicle quality that incorporates Flash for storing voice code data, and can be controlled with a standalone interface.

By integrating all the functions required for voice output into a single chip, this LSI can be more easily incorporated in compact portable devices.

- Playback time

Product name	Flash capacity (bit)	Maximum playback time (sec) (at fs = 6.4 kHz)	
		4-bit ADPCM2	16-bit PCM
ML22Q284	692K	27.6	6.9

Notes: Flash capacity shows the numerical value of only a voice area

- Speech synthesis method: 4-bit ADPCM2
8-bit Nonlinear PCM
8-bit PCM , 16-bit PCM
(Method can be specified for each phrase)
- Flash capacity: 692 Kbit
- Sampling frequency (Fs): 8.0/16.0/32.0 kHz, 6.4/12.8/25.6 kHz, 10.7/21.3 kHz
(Can be specified for each phrase)
- Speaker driving amplifier: D-class amplifier (driven by 8 Ω)
- CPU command interface: Standalone interface (built-in noise removal function)
- Maximum number of phrases: 30 phrases
- Disconnection detection function /Speaker pin short detection function
- Source oscillation frequency: 4.096 MHz (Typ) (internal)
- Power supply voltage: 2.0 to 5.5 V
- Flash memory rewritable time: 80 times
- Operating temperature range: -40 °C to +105 °C
- AEC-Q100: Compliant
- Package: 20-pin plastic TSSOP
ML22Q284-NNNTD/ML22Q284-xxxTD
(xxx: ROM code No.)

The following table shows the differences from ML22Q274, ML22Q294.

Parameter	ML22Q284	ML22Q274	ML22Q294
MCU interface	Standalone	Clock synchronization Serial	I2C
Flash capacity	692 Kbit	692 Kbit (when 30 phrases are selected) 688 Kbit (when 62 phrases are selected)	←
Playback method	4-bit ADPCM2 8-bit Nonlinear PCM 8-bit PCM 16-bit PCM	←	←
Maximum number of phrases:	30	30/62	←
Sampling frequency (kHz)	6.4/8.0/10.7/12.8/ 16.0/21.3/25.6/32.0	←	←
Clock frequency	4.096 MHz (internal oscillation)	←	←
Low-pass filter	FIR interpolation filter	←	←
Speaker driving amplifier	D-class amplifier	←	←
Speaker driving amplifier output load	8Ω	←	←
Speaker driving amplifier output voltage	1 W (Ta = -40 to +85°C) 0.8 W (Ta = -40 to +105°C)	←	←
Edit ROM function	Yes	←	←
Volume control	32 levels	←	←
Silence insertion	4 ms to 1024 ms (4 ms/step)	←	←
Repeat function	Yes	←	←
Power supply voltage	2.0 to 5.5 V	←	←
Operating temperature range	-40 to +105°C	←	←
Package	20-pin TSSOP	←	←

■ BLOCK DIAGRAMS

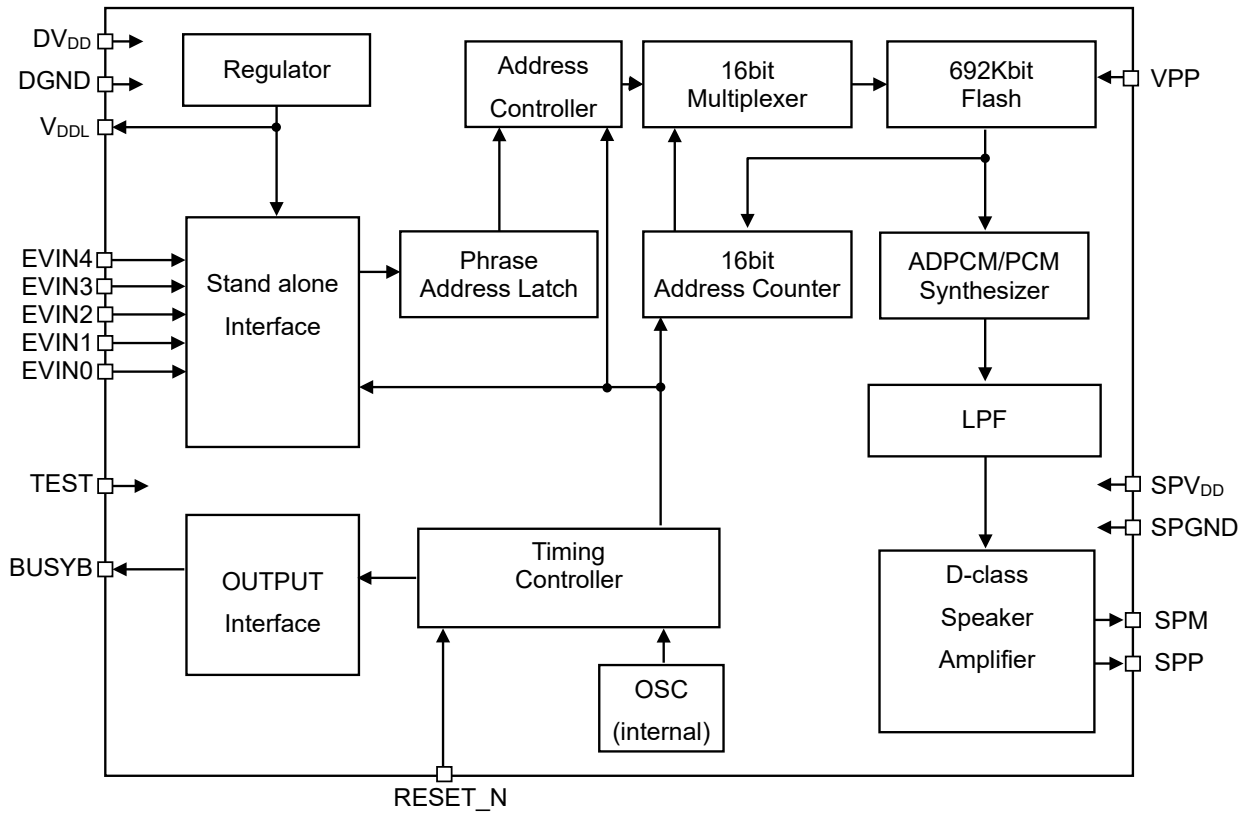

■ PIN CONFIGURATIONS (TOP VIEW)

20-Pin Plastic TSSOP

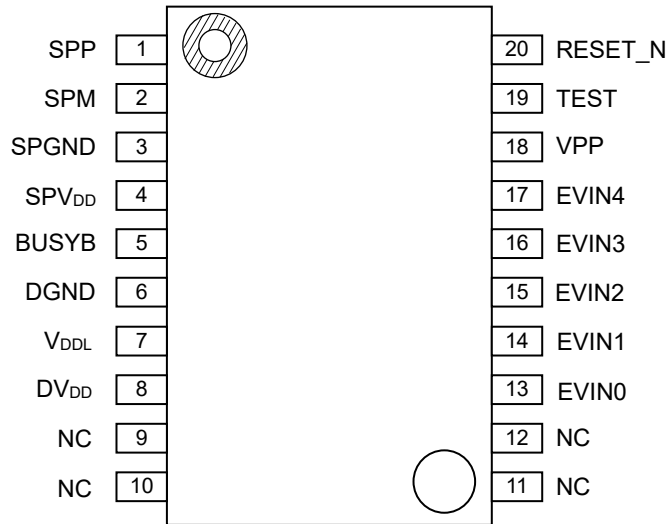

NC: Unused pin

■ PIN DESCRIPTION

Pin	Symbol	I/O	Initial value (At the RESET_N Input)	Initial value (At standby)	Description
1	SPP	O	Hi-Z	Hi-Z	Positive (+) output pin of the speaker amplifier built-in
2	SPM	O	Hi-Z	Hi-Z	Negative (-) output pin of the speaker amplifier built-in.
3	SPGND	-	-	-	Ground pin for the speaker amplifier.
4	SPV _{DD}	-	-	-	Power supply pin for the speaker amplifier Connect a bypass capacitor of 0.1 μ F or more between this pin and SPGND pin.
5	BUSYB	O	Hi-Z	1	BUSY output pin. When BUSYB use mode is set, the "L" level is outputted during playback. When disconnection is detected with disconnection detection function, the "L" level is outputted. BUSYB unused mode and logic inversion can be set with Speech LSI Utility.
6	DGND	-	-	-	Digital ground pin.
7	V _{DDL}	-	-	-	Regulator output pin for internal logic circuitry. Connect a capacitor of 10 μ F or more between this pin and DGND pin
8	DV _{DD}	-	-	-	Digital power supply pin. Connect a capacitor of 0.1 μ F or more between this pin and DGND pin.
13	EVIN0	I	0	0	Command input pin.
14	EVIN1	I			Voice can be played back and stopped based on a change in a signal input to EVIN4-0 pin.
15	EVIN2	I			The pin state can be set with Code Option Setting when a voice code is generated.
16	EVIN3	I			EVIN0 pin: select pull-up input or high impedance input
17	EVIN4	I			EVIN4-1 pin: select pull-down input, pull-up input, or high impedance input
18	VPP	-	-	-	Power supply pin for rewriting Flash memory. Fix this pin to GND except when rewriting Flash memory
19	TEST	I	0	0	Test pin. Fix this pin to DGND.
20	RESET_N	I	0	1	Reset pin. Input "L" level for initialization, when power is turned on, or when voltage falls below recommended operation power supply voltage range. After the power supply voltage is stable, drive this pin to "H" level.
9 10 11 12	N.C.	-	-	-	Unused pin. Leave this pin open.

■ ABSOLUTE MAXIMUM RATINGS

(DGND = 0 V)				
Parameter	Symbol	Condition	Rating	Unit
Power supply voltage	DV _{DD} SPV _{DD}	Ta = 25 °C	-0.3 to + 7.0	V
Internal logic power supply voltage	V _{DDL}		-0.3 to +3.6	V
Flash power supply voltage	V _{PP}		-0.3 to +9.5	V
Input voltage	V _{IN}		-0.3 to V _{DD} +0.3	V
Power dissipation	P _D		1	W
Output short-circuit current	I _{SC1}	Applied to pin other than SPP or SPM	-12 to +11	mA
	I _{SC2}	SPP pin, SPM pin	600	mA
Storage temperature	T _{STG}	-	-55 to +150	°C

■ RECOMMENDED OPERATING CONDITIONS

(DGND = 0 V)				
Parameter	Symbol	Condition	Range	Unit
Power supply voltage	DV _{DD} SPV _{DD}	-	2.0 to 5.5	V
		Flash memory write	2.7 to 5.5	
Flash power supply voltage	V _{PP}	Flash memory write	7.7 to 8.3	V
Flash memory rewrite cycles	N	-	80	times
Operating temperature range	T _{OP1}	-	-40 to +105	°C
	T _{OP2}	Flash memory write	0 to +40	

■ ELECTRICAL CHARACTERISTICS

● DC Characteristics

 $DV_{DD} = SPV_{DD} = 2.0 \text{ to } 5.5 \text{ V}, DGND = SPGND = 0 \text{ V}, T_a = -40 \text{ to } +105^\circ\text{C}$

Parameter	Symbol	Condition	Min.	Typ.	Max.	Unit
"H" input voltage	V_{IH}	-	$0.7 \times DV_{DD}$	-	DV_{DD}	V
"L" input voltage	V_{IL}	-	0	-	$0.3 \times DV_{DD}$	V
"H" output voltage 1	V_{OH1}	$I_{OH} = -0.5 \text{ mA}$	$DV_{DD} - 0.5$	-	-	V
"L" output voltage 1	V_{OL1}	$I_{OL} = 0.5 \text{ mA}$	-	-	0.5	V
"H" input current 1	I_{IH1}	$V_{IH} = DV_{DD}$	-	-	1	μA
"H" input current 2	I_{IH2}	$V_{IH} = DV_{DD}$ TEST pin	0.02	0.3	1.5	mA
"H" input current 3	I_{IH3}	$V_{IH} = DV_{DD}$ EVIN4-1 terminal pull-up input is set	0.02	0.3	1.5	mA
"L" input current 1	I_{IL1}	$V_{IL} = DGND$	-1	-	-	μA
"L" input current 2	I_{IL2}	$V_{IL} = DGND$ RESET N pin	-1.5	-0.3	-0.02	mA
"L" input current 3	I_{IL3}	$V_{IL} = DGND$ EVIN4-0 terminal pull-up input is set	-1.5	-0.3	-0.02	mA
"H" output current 1	I_{OOH1}	$VOH = DV_{DD} = SPV_{DD}$ (High impedance) BUSYB, SPP, SPM pin	-	-	1	μA
"H" output current 2	I_{OOH2}	$VOH = DV_{DD}$ (Nch Open drain) BUSYB pin	-	-	1	μA
"L" output current 1	I_{OOL1}	$VOL = DGND = SPGND$ (High impedance) BUSYB, SPP, SPM pin	-1	-	-	μA
"L" output current 2	I_{OOL2}	$VOL = DGND$ (Pch Open drain) BUSYB pin	-1	-	-	μA
Supply current during playback	I_{DD1}	No output load $DV_{DD} = SPV_{DD} = 3.0 \text{ V}$	-	4.0	6.0	mA
	I_{DD2}	No output load $DV_{DD} = SPV_{DD} = 5.0 \text{ V}$	-	6.0	10	
Supply current during stabilizing chattering	I_{DDC1}	$DV_{DD} = SPV_{DD} = 5.0 \text{ V}$	-	3.0	5.0	mA
Standby supply current	I_{DDS1}	$T_a \leq 40^\circ\text{C}$	-	0.5	3.0	μA
	I_{DDS2}	$T_a \leq 85^\circ\text{C}$	-	0.5	8.0	
	I_{DDS3}	$T_a \leq 105^\circ\text{C}$	-	0.5	16.0	
Source oscillation frequency	f_{OSC}	-10 to $+50^\circ\text{C}$	4.034	4.096	4.158	MHz
		-40 to $+105^\circ\text{C}$	3.973	4.096	4.219	

● Characteristics of Analog Circuitry

 $DV_{DD} = SPV_{DD} = 2.0 \text{ to } 5.5 \text{ V}, DGND = SPGND = 0 \text{ V}, T_a = -40 \text{ to } +105^\circ\text{C}$

Parameter	Symbol	Condition	Min.	Typ.	Max.	Unit
SPM, SPP output load resistance	R_{LSP}	-	8	-	-	Ω
Speaker amplifier output voltage	P_{SPO}	$SPV_{DD} = 5.0 \text{ V}$, Sin wave $f = 1 \text{ kHz}$ $R_{LSP} = 8 \Omega$, THD $\geq 10\%$ $T_a = -40 \text{ to } +85^\circ\text{C}$	-	1.0	-	W
		$SPV_{DD} = 5.0 \text{ V}$, Sin wave $f = 1 \text{ kHz}$ $R_{LSP} = 8 \Omega$, THD $\geq 10\%$ $T_a = -40 \text{ to } +105^\circ\text{C}$	-	0.8	-	W

- AC Characteristics

 $DV_{DD} = SPV_{DD} = 2.0 \text{ to } 5.5 \text{ V}$, $DGND = SPGND = 0 \text{ V}$, $T_a = -40 \text{ to } +105^\circ\text{C}$

Parameter	Symbol	Condition	Min.	Typ.	Max.	Unit
RESET_N input pulse width	t _{RST}	-	100	-	-	μs
Start time SPV _{DD} after starting DV _{DD}	t _{VDD}	-	0	-	-	ns
Initialization time after reset release	t _{INIT}	-	-	-	65	ms
Oscillation stable time	t _{PUP1}	-	-	1	2	ms
Playback time	t _{VCYC}	-	20	-	-	ms
Chattering removal time* ¹	t _{SP}	Initial value (08 h)	Typ.-2	16	Typ.+2	ms
Command processing time	t _{B1}	-	-	-	400	μs
Oscillation stop time, after playback	t _{OSST}	-	-	-	500	μs
Next command transmit time□ In the case of the playback	t _{NCM}	-	-	-	10	ms
Next command transmit time after shifting to a standby state	t _{CMS}	-	50	-	-	ns
Disconnection judging by the DISCONNECT command start time	t _{DCDS}	-	1.5	-	-	ms
Disconnection judging by the DISCONNECT command end time	t _{DCDE}	-	-	-	1	s
BUSYB change time from "L" to "H", after over-current detection of a speaker amplifier	t _{SD}	-	-	-	80	μs
Processing time before playback start	t _{PLBF}	-	0.3	-	2.1	ms
Processing time after playback start	t _{PLAF}	-	0.15	-	1.2	ms
Fade-out time at Change Immediately mode or Change Immediately Once mode	t _{FDO}	-	-	22	-	ms

Note 1 : Can be set within a range from 0 ms to 62 ms with Speech LSI Utility.

Note : Output pin load capacitance = 45 pF (max.)

■ FUNCTIONAL DESCRIPTION

● Standalone interface

Standby is canceled by a change in a signal input to the EVIN4-0 pin, and after the chattering removing period, an operation corresponding to a command indicated by the EVIN4-0 pin starts.

The pin status of the EVIN0 pin can be selected between high-impedance input (Hi-Z) and pull-up input (PullUp). The pin status of the EVIN4-1 can be selected among high-impedance input (Hi-Z), pull-down input (PullDown), and pull-up input (PullUp).

The pin status of the EVIN4-0 pin is selected using Speech LSI Utility.
Please refer to a "Code Option Setting Item" for details.

● Chattering removal time

Chattering removal time can be set for preventing erroneous operation due to chattering when the EVIN4-0 pin changes. The time can be set from 2 ms to 62 ms (setting value: 01h to 1Fh) in increments of 2 ms. The initial value is 16 ms (08h).

$$\text{Chattering removal time} = (2^4 \cdot \text{bit4} + 2^3 \cdot \text{bit3} + 2^2 \cdot \text{bit2} + 2^1 \cdot \text{bit1} + 2^0 \cdot \text{bit0}) \cdot 2 \text{ ms}$$

Set a setting value 10h to set the time to be 32 ms.

$$\text{Chattering removal time} = 2^4 \cdot 1 + 2^3 \cdot 0 + 2^2 \cdot 0 + 2^1 \cdot 0 + 2^0 \cdot 0) \cdot 2 \text{ ms} = 8 \cdot 2 \text{ ms} = 32 \text{ ms}$$

The chattering removal time is selected using Speech LSI Utility.
Please refer to a "Code Option Setting Item" for details.

● Speech synthesis method

Supporting four types of speech synthesis methods, which are 4bit ADPCM2, 8-bit nonlinear PCM, 8-bit PCM, and 16-bit PCM. Any of these can be selected based on the characteristics of the voice to be played back.

Speech synthesis method	Compression rate*1	Suitable waveform	Characteristics
4-bit ADPCM2	1/4	Normal voice sound wave	Unique scheme which is a refined version of 4bit ADPCM Offers higher sound quality with better waveform followability.
8-bit Nonlinear PCM	1/2	Sound including high frequency components (such as sound effects)	A part around the center of the waveform is played back with a sound quality equivalent to 10 bits.
8-bit PCM	1/2		Normal 8-bit PCM.
16-bit PCM	1		Normal 16-bit PCM.

Note 1: When the same sampling frequency is used.

- Memory Allocation and Creating Voice Data

The voice code data consists of a voice management area, a voice data area, and an edit ROM area.

The voice control area manages voice data for 30 phrases.

The voice area contains actual waveform data.

The edit ROM area contains data for effective use of voice data. For the details, refer to the section of “Edit ROM Function”. The edit ROM area only available when the edit ROM is used.

The ROM data is created using Speech LSI Utility.

Please refer to a "Code Option Setting Item" for details.

Voice code data configuration

0x00000	Voice control area
0x001FF	
0x00200	Voice data area / Edit ROM area*1
0x159FF	

*1: Edit ROM area depends on creation of the data

- Playback Time and Flash Capacity

The playback time depends on the memory capacity, sampling frequency, and the playback method. The equation to know the playback time is shown below. But this is not applied if the edit ROM function is used.

$$\text{Playback time [sec]} = \frac{1.024 \times (\text{Voice data area/Edit ROM area}) \text{ (Kbit)}}{\text{Sampling frequency [kHz]} \times \text{Bit length}}$$

(Bit length is 4 at the 4-bit ADPCM2 and 8/16 at the PCM.)

In the case that the sampling frequency is 8 kHz, algorithm is 4-bit ADPCM2, the playback time is approx. 22.1 seconds.

$$\text{Playback time} = \frac{1.024 \times 692 \text{ (Kbit)}}{8 \text{ (kHz)} \times 4 \text{ (bit)}} \approx 22.1 \text{ [sec]}$$

Make the playback time of one phrase more than 20 msec.

- Edit ROM function

The edit ROM function makes it possible to play back multiple phrases in succession. The following functions are set using the edit ROM function:

- Continuous playback: There is no limit to set the number of times of the continuous playback. It depends on the Flash capacity only.
- Silence insertion function: 4 ms to 1,024 ms

*Note: Silent insertion time varies for ± 1 ms depends on the sampling frequency.
An independent phrase generated by edit ROM shall be 20 ms or longer.

It is possible to use voice ROM effectively to use the edit ROM function.
An example of the ROM structure, in a case of using the edit ROM function is as follows.

Example 1) Phrases using the Edit ROM Function

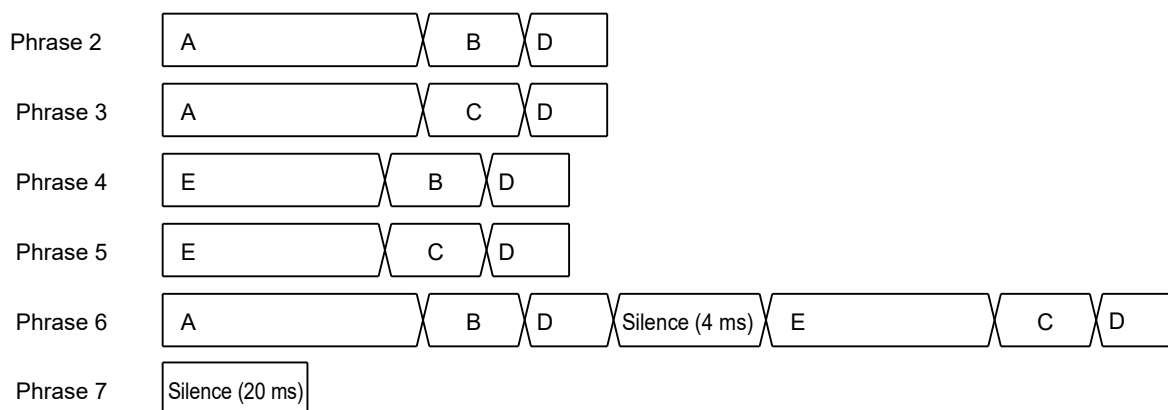

Example 2) Structure of the ROM storing contents of Example 1

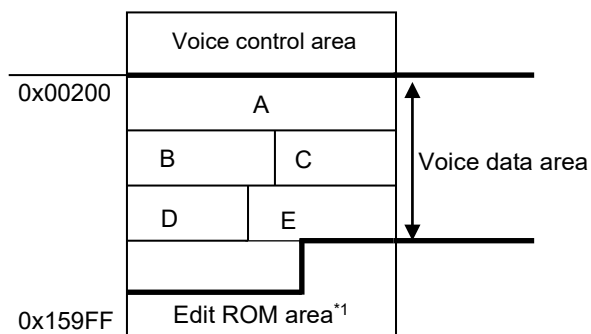

*1: Information on phrases 2 to 7 stored

● Playback mode setup

Five playback modes are available. Can be set up for every phrase.
Set when the voice code data is generated.

◆ Play Once mode

This mode is playback once.
All the commands become invalid during playback.

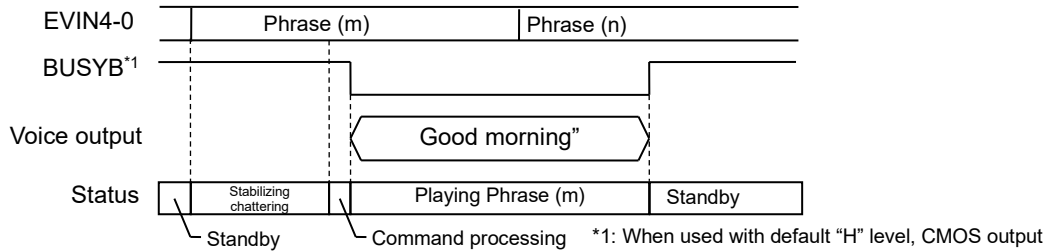

Next command must be input in the standby state after the playback ends.

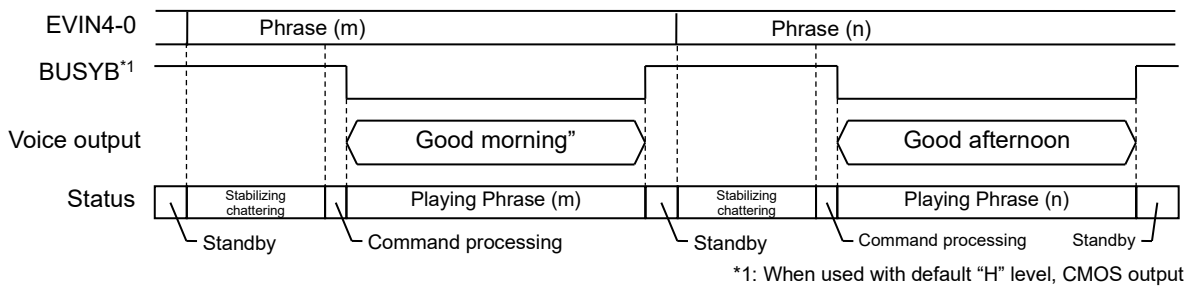

◆ Scheduled Play Once mode

This mode is playback once.
When the next phrase is inputted during playback, after playback of the present phrase ends, playback of the next phrase starts. When the following phrase is inputted into playback, after playback of the present phrase is completed, playback of the following phrase starts.

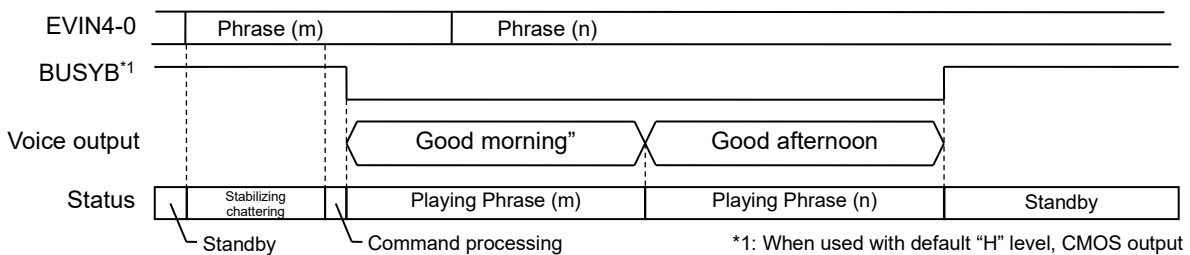

When a plurality of commands are input, the last command input at the end of the phrase is valid.
In the following case, the phrase (n) is not played back because the last command is STOP command.

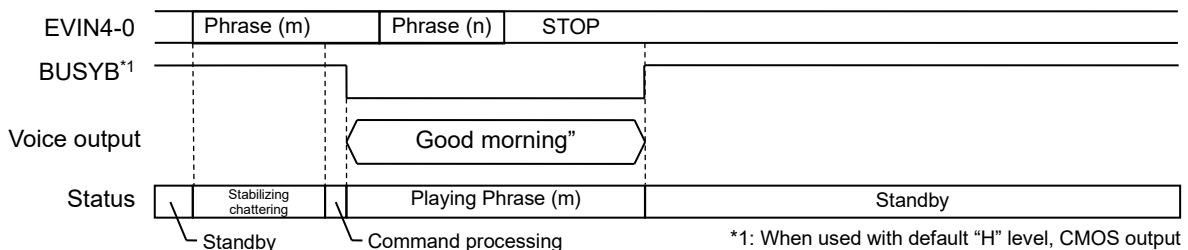

◆ Change Immediately Once mode

This mode is for playing back once.

When the following phrase is inputted into playback, playback of the present phrase is ended on the way, and playback of the following phrase starts.

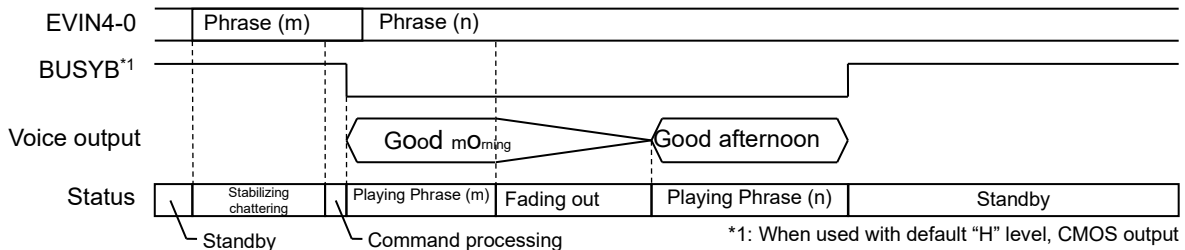

When a plurality of commands are input, the last command input at the end of the phrase is valid.

In the following case, the last input phrase (o) is played back.

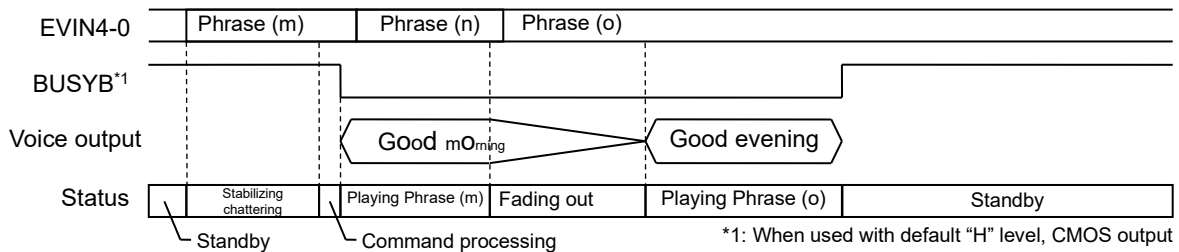

◆ Scheduled Play mode

Once the playback starts, it is repeated until the next command is input.

The next command input during the playback is executed after the playback ends.

When a plurality of commands are input, the last command input at the end of the phrase is valid, as in Scheduled Play Once.

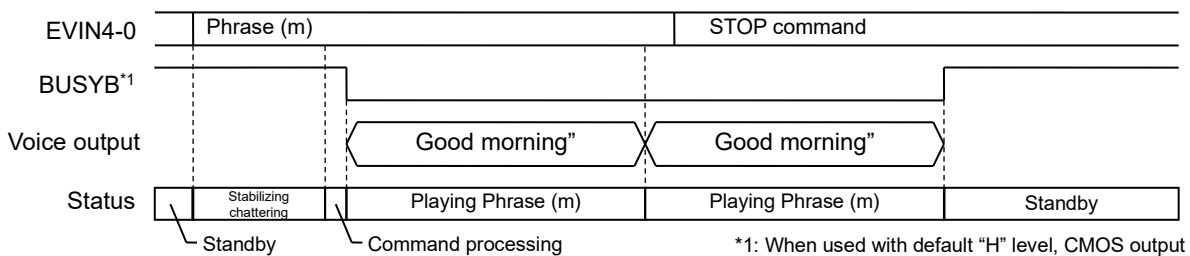

◆ Change Immediately mode

Once the playback starts, it is repeated until the next command is input.

When the next command is input, the phrase being played back is terminated, and the next command is executed. When the following command is inputted into playback, playback of the present phrase is ended on the way, and playback of the following command starts.

When a plurality of commands are input, the last command input at the end of the phrase is valid, as in Change Immediately Once.

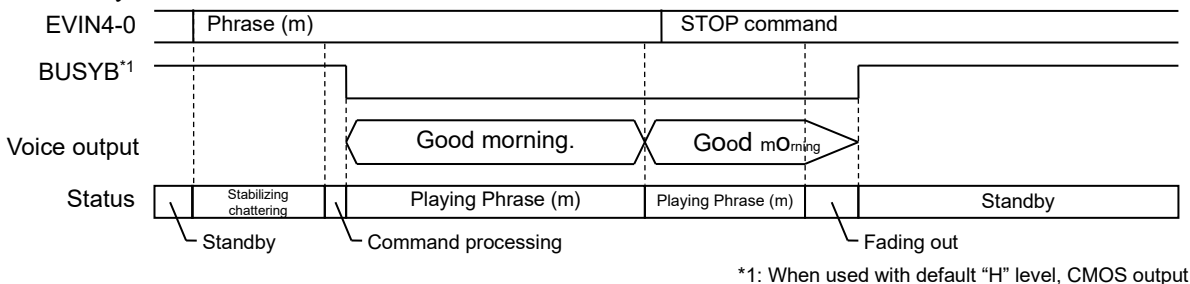

● Volume setup function

Each phrase can set up the volume setup.
Set when the voice code data is generated.

Value	Volume [dB]	Value	Volume [dB]	Value	Volume [dB]
00h	+2.98	0Ah	-0.41	15h	-6.87
01h	+2.70	0Bh	-0.83	16h	-7.79
02h	+2.40	0Ch	-1.28	17h	-8.82
03h	+2.10	0Dh	-1.75	18h	-9.99
04h	+1.78	0Eh	-2.25	19h	-11.34
05h	+1.45	0Fh	-2.77	1Ah	-12.94
06h	+1.11	10h	-3.34	1Bh	-14.90
07h	+0.76	11h	-3.94	1Ch	-17.44
08h	+0.39	12h	-4.58	1Dh	-21.04
09h	+0.00	13h	-5.28	1Eh	-27.31
		14h	-6.04	1Fh	OFF

● Function of setting wait time before and after playback (WS1, WS2, WS3, WS4)

Wait time before playback (WS1, WS2) and after playback (WS3, WS4) can be set for each phrase.
Set when the voice code data is generated.

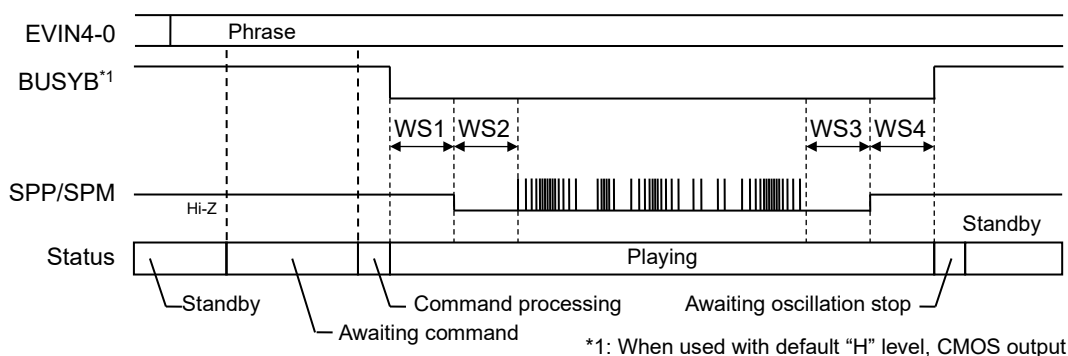

- WS1: Time after inputting a phrase address, until SPP/SPM pins are enabled.
- WS2: Time after SPP/SPM pins are enabled, until playback is started.
- WS3: Time after playback is completed, until SPP/SPM pins are disabled.
- WS4: Time after SPP/SPM pins are disabled, until it will be in a standby state.

WS1-WS4 can be arbitrarily set up between 0 to 1020 ms (4 ms unit).

- Speaker Pin Short Detection Function

The speaker pin short detection function detect the short-circuit between SPP pin and SPM pin, or between SPP/SPM pin and GND during playback.

When short-circuit of a speaker pin is detected, the playback will be stopped automatically, BUSYB pin will become "H" level, and LSI will become in a standby state.

Speaker short detection prevents IC destruction, but the detection circuit is effective to prevent destruction caused by sudden accidents, and is not intended for use in the condition like short detection occurs continuously.

This function can be set up with the option screen of Speech Utility.

Please refer to a "Code Option Setting Item" for details.

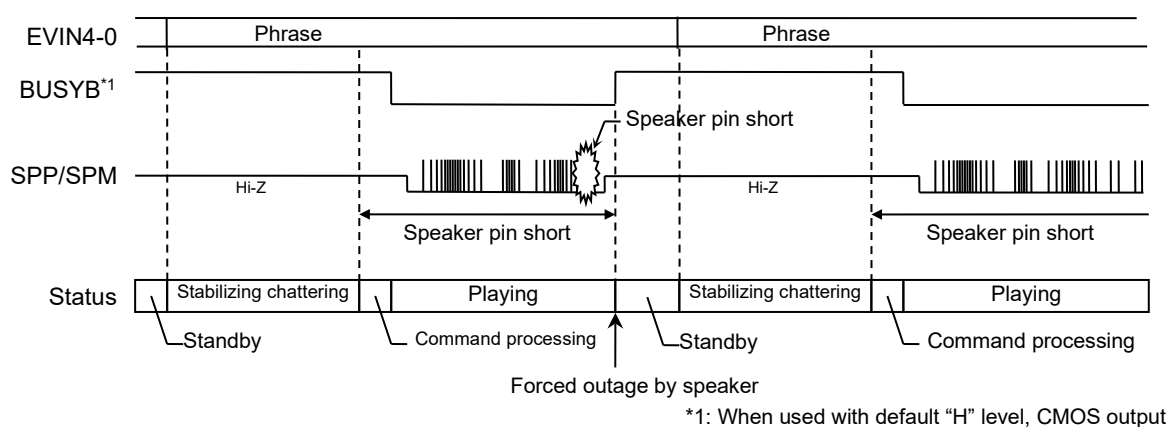

■ Commands

The following commands are used for the LSI. After setting the voice code data in the flash memory of this LSI, be sure to use the voice playback command.

Command	Description
STOP	Stop command. The STOP command becomes effective for phrase other than those in Play Once mode and Scheduled Play Once mode.
DISCONNECT	Disconnection detection command. Speaker disconnection is detected. The STOP command must be input after using the DISCONNECT command.
PHRASE	Playback command. Playback phrase is selected from 30 phrases.

● Command configuration

Command is of 1 byte, and any bit sequence can be set for STOP command and DISCONNECT command. PHRASE command is allocated with a bit sequence other than the set values for STOP command and DISCONNECT command.

These are set when the voice code data is generated.
Please refer to a "Code Option Setting Item" for details.

The command configuration when the initial value (STOP command is set to be 00000b and DISCONNECT command is set to be 00001b) is set is as follows.

Command	EVIN4	EVIN3	EVIN2	EVIN1	EVIN0
STOP	0	0	0	0	0
DISCONNECT	0	0	0	0	1
PHRASE	0	0	0	1	0
	:				
	1	1	1	1	1

Example where STOP command is set to 11111b and DISCONNECT command is set to 00001b is described.
When STOP command is changed from the initial value, the number of phrase available decreases by one.

Command	EVIN4	EVIN3	EVIN2	EVIN1	EVIN0
_*1	0	0	0	0	0
DISCONNECT	0	0	0	0	1
PHRASE	0	0	0	1	0
	:				
	1	1	1	1	0
STOP	1	1	1	1	1

Note 1: 00000b cannot be set to PHRASE command. 29 phrases from 00010b to 11110b can be set to PHRASE command.

● STOP command

EVIN4-0 pin	EVIN4	EVIN3	EVIN2	EVIN1	EVIN0
Initial value	0	0	0	0	0

The STOP command is used to stop the playback. BUSYB pin will become “H”, if the playback is stopped.

The STOP command becomes effective for the phrase waiting to be played in Scheduled Play Once mode, and in Scheduled Play mode, Change Immediately Once mode, and Change Immediately mode.

STOP command used for phrases played back in Play Once mode or Scheduled Play Once mode, the STOP is ignored.

When STOP command is input in Scheduled Play mode, the playback stops after the phrase is played back to the end.

When STOP command is input in Change Immediately Once mode or Change Immediately mode, the voice fades out, and the playback stops.

Input a phrase playback request (PHRASEn command) after the STOP command, after confirming the end of the phrase being played (BUSYB="H"), and after $t_{OSST}+t_{CMS}$ has elapsed.

Operations where STOP command is effective are described below.

◆ STOP command operation in the case of Scheduled Play Once mode

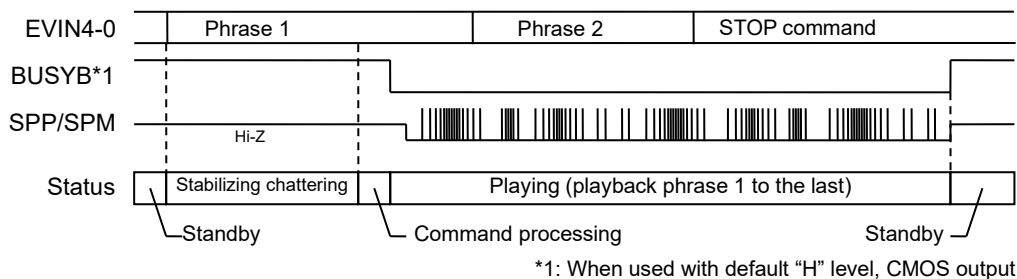

◆ STOP command operation in the case of Scheduled Play mode

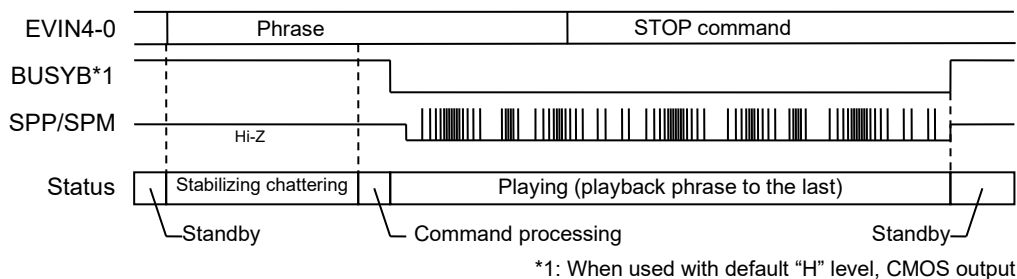

◆ STOP command operation in the case of Change Immediately Once mode or Change Immediately mode

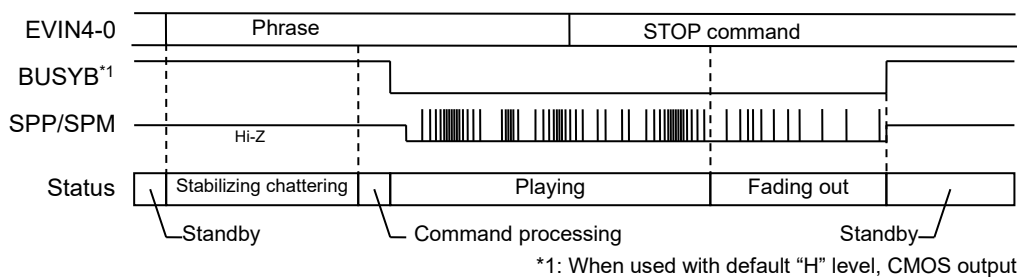

• DISCONNECT command

EVIN4-0 pin	EVIN4	EVIN3	EVIN2	EVIN1	EVIN0
Initial value	0	0	0	0	1

The DISCONNECT command is used to diagnose whether the speaker is disconnected or not. The command cannot be used during voice playback. The command shall be used during standby (no playback). Disconnection detection result is output to BUSYB pin. "L" is output when the speaker is disconnected, and outputs "H" when the speaker is not disconnected. Please input the STOP command to transition to standby state, after you use the DISCONNECT command.

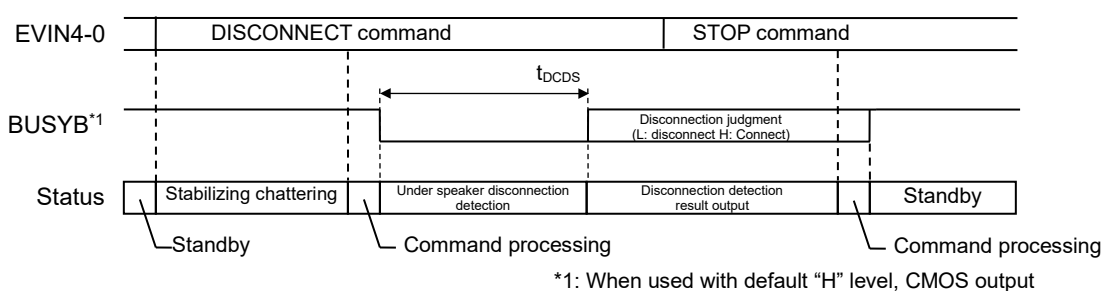

When no STOP command is input after the execution of DISCONNECT command, the disconnection detection automatically stops in one second, and transition to standby occurs.

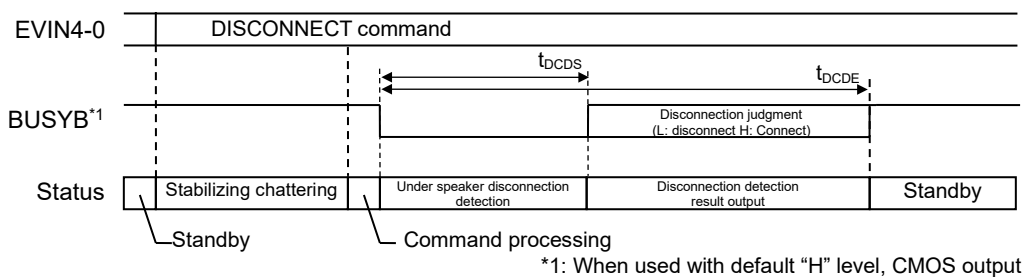

- PHRASE command

EVIN4-0 pin	EVIN4	EVIN3	EVIN2	EVIN1	EVIN0
	0	0	0	1	0
Initial value	:				
	1	1	1	1	1

PHRASE command is playback command. Specifies an address of a phrase to be played back. Command that is not set to be STOP command or DISCONNECT command is set to be PHRASE command. An address of phrase to be played back is set when voice code data is generated with Speech LSI Utility.

Timings of PHRASE command are shown below.

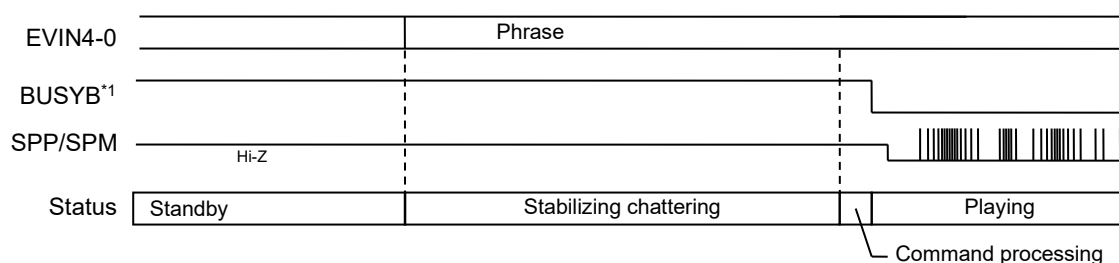

*1: When used with default "H" level, CMOS output

■ TIMING DIAGRAMS

● Power-On Timing

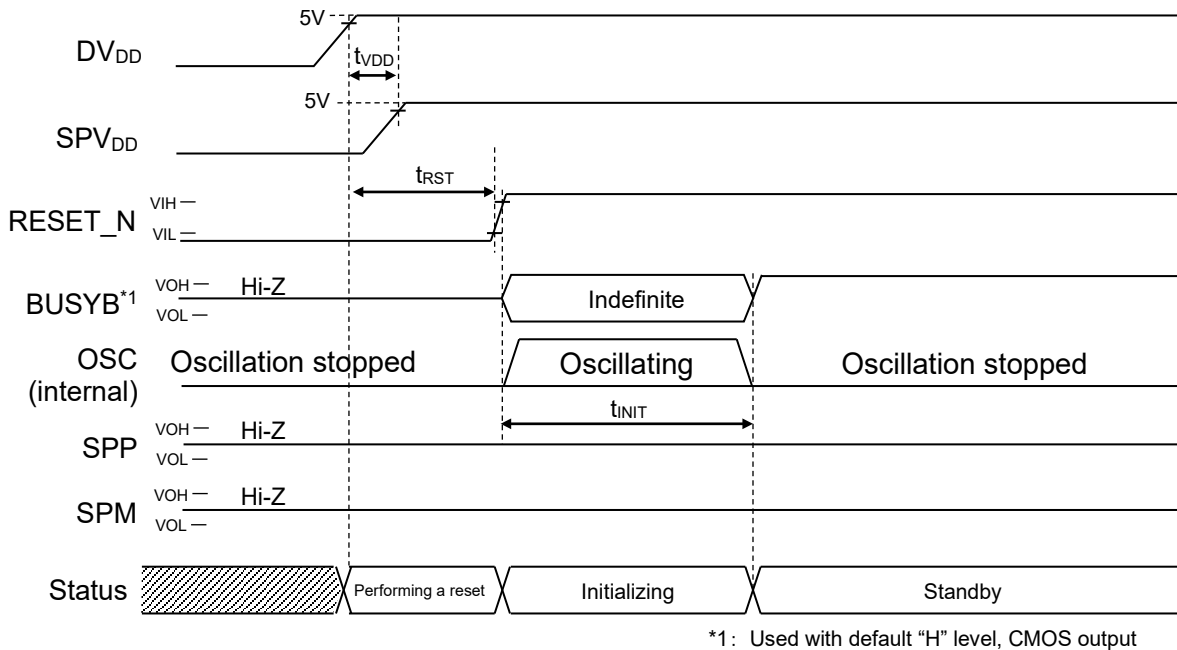

Turn on DV_{DD} and SPV_{DD} simultaneously, or turn on SPV_{DD} after turning on DV_{DD}.
 Turn on DV_{DD} and SPV_{DD} simultaneously, or turn on SPV_{DD} after turning on DV_{DD}.
 When DV_{DD} or SPV_{DD} falls below recommended operation power supply voltage range, "L" level must be input to RESET_N pin.

● Power down timing (RESET_N pin)

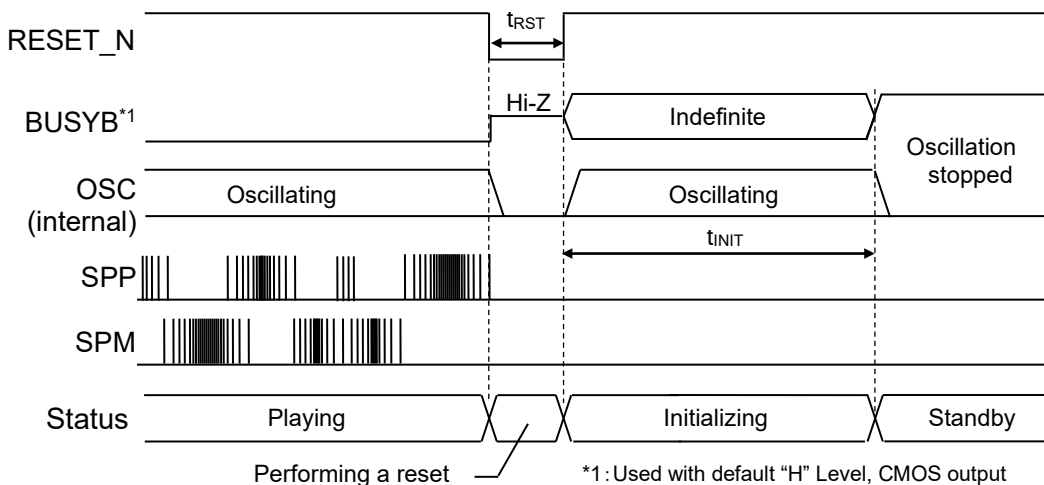

When DV_{DD} or SPV_{DD} falls below recommended operation power supply voltage range, "L" level must be input to RESET_N pin.

• Play Oncemode/Scheduled Play Once/Change Immediately Once timing

After playback of phrase (m) ends, playback request for next phrase (n) is accepted and the phrase (n) is played back. All the commands become invalid during playback of phrase (m).

After BUSYB has shifted to "H" level, input the PHRASE command after $t_{OSST} + t_{CMS}$ has elapsed.

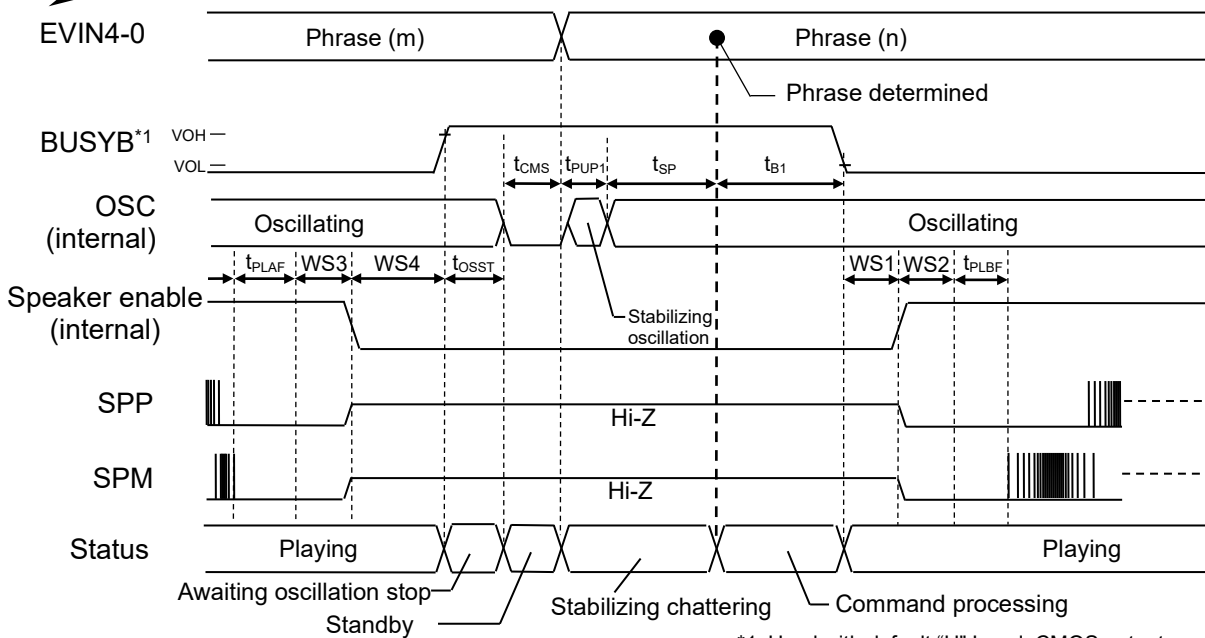
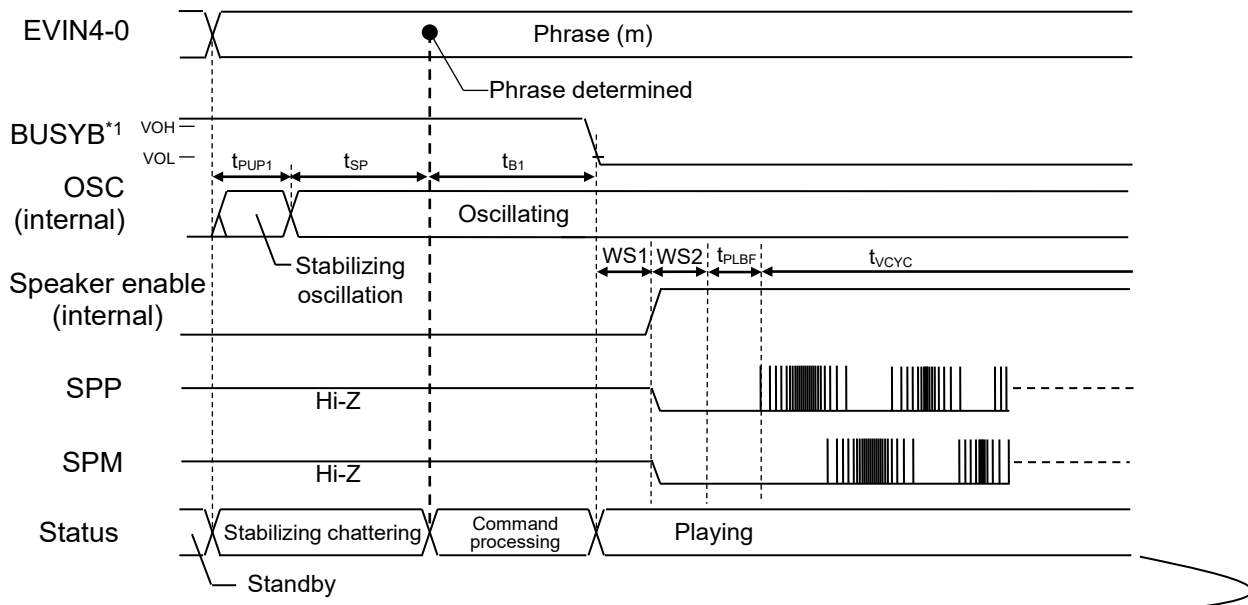

*1: Used with default "H" Level, CMOS output

• Scheduled Play Once mode and Scheduled Play mode Timing (Continuous Play)

In response to playback request for the next phrase (n), the phrase (m) is played back to the end, and then playback of the phrase (n) starts.

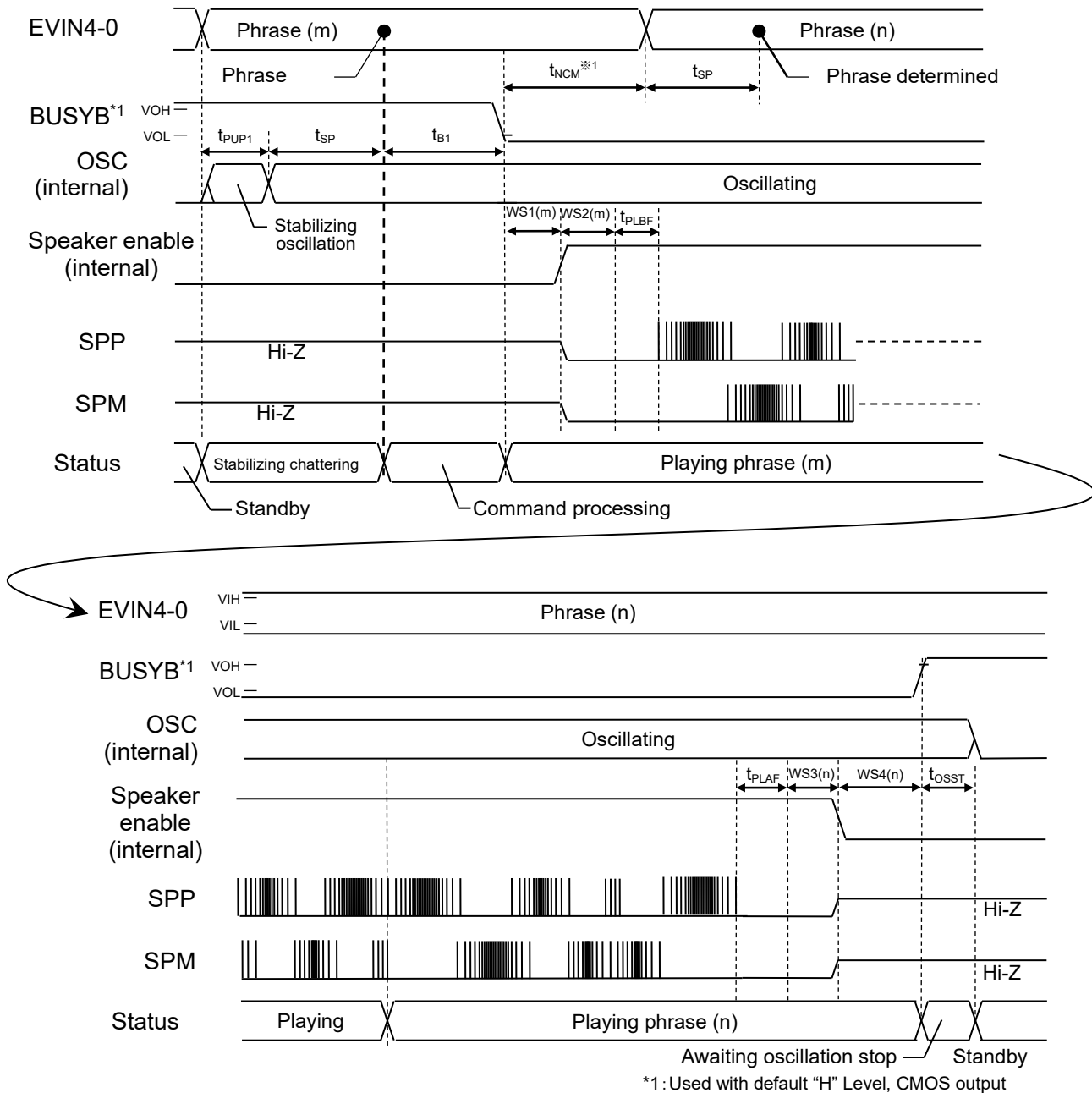

*Under Scheduled Play mode, playback is stopped by STOP command.

Note 1: In Scheduled Play Once mode, the phrase (n) is played back immediately after the end of the playback of the phrase (m), in response to an input of a playback request (PHRASE command) for the next phrase (phrase (n)) within t_{NCM} .

- Change Immediately Once mode and Change Immediately mode Timing (Continuous Play)

In response to playback request for the next phrase (n), the phrase (m) is played back to the last, and then playback of the phrase (n) starts.

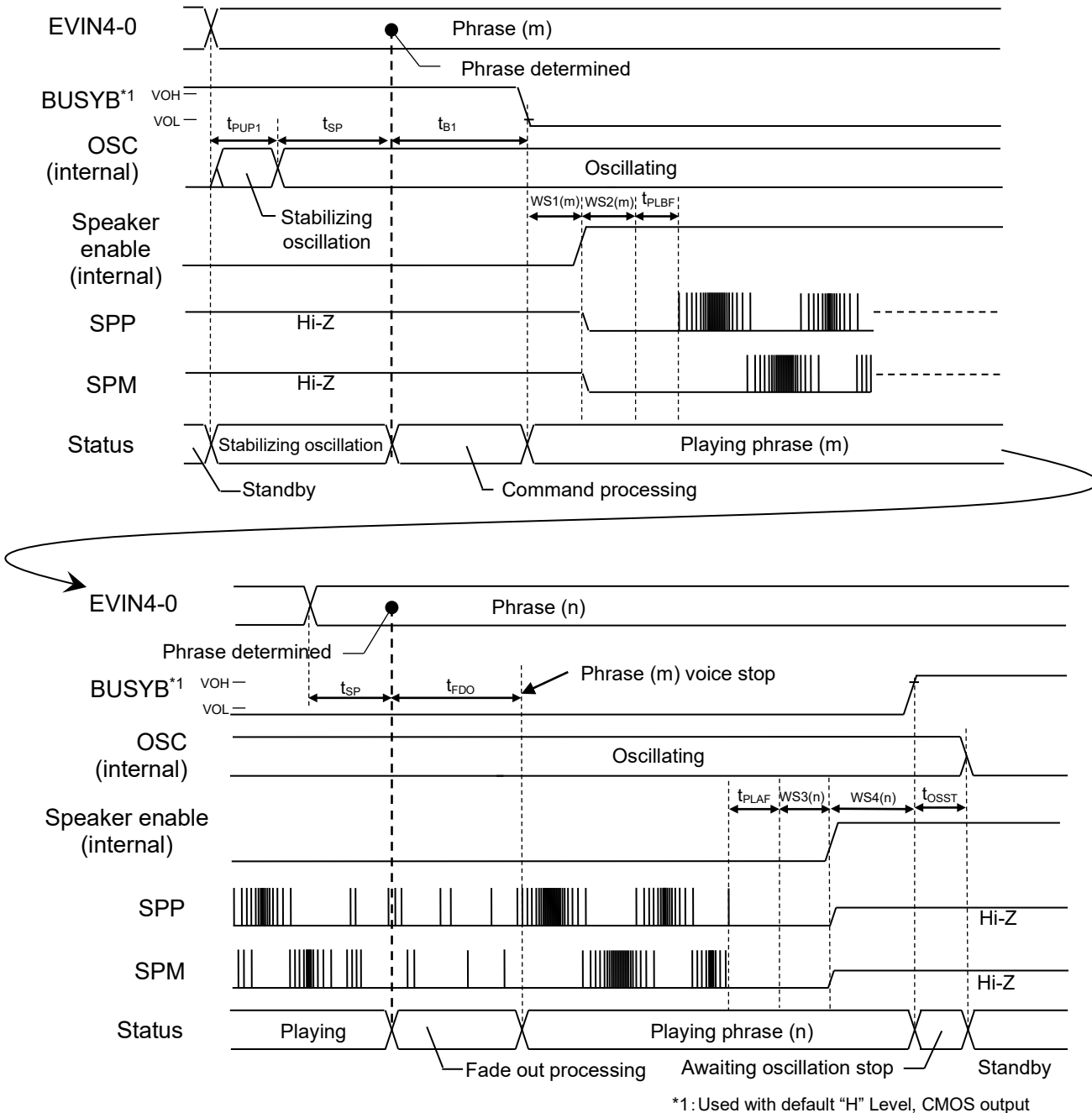

- Under Change Immediately mode, playback is stopped by STOP command.

- Scheduled Play Once mode and Scheduled Play mode Timing voice stop timing

After STOP command is input, the phrase is played back until the end, and the playback stops.

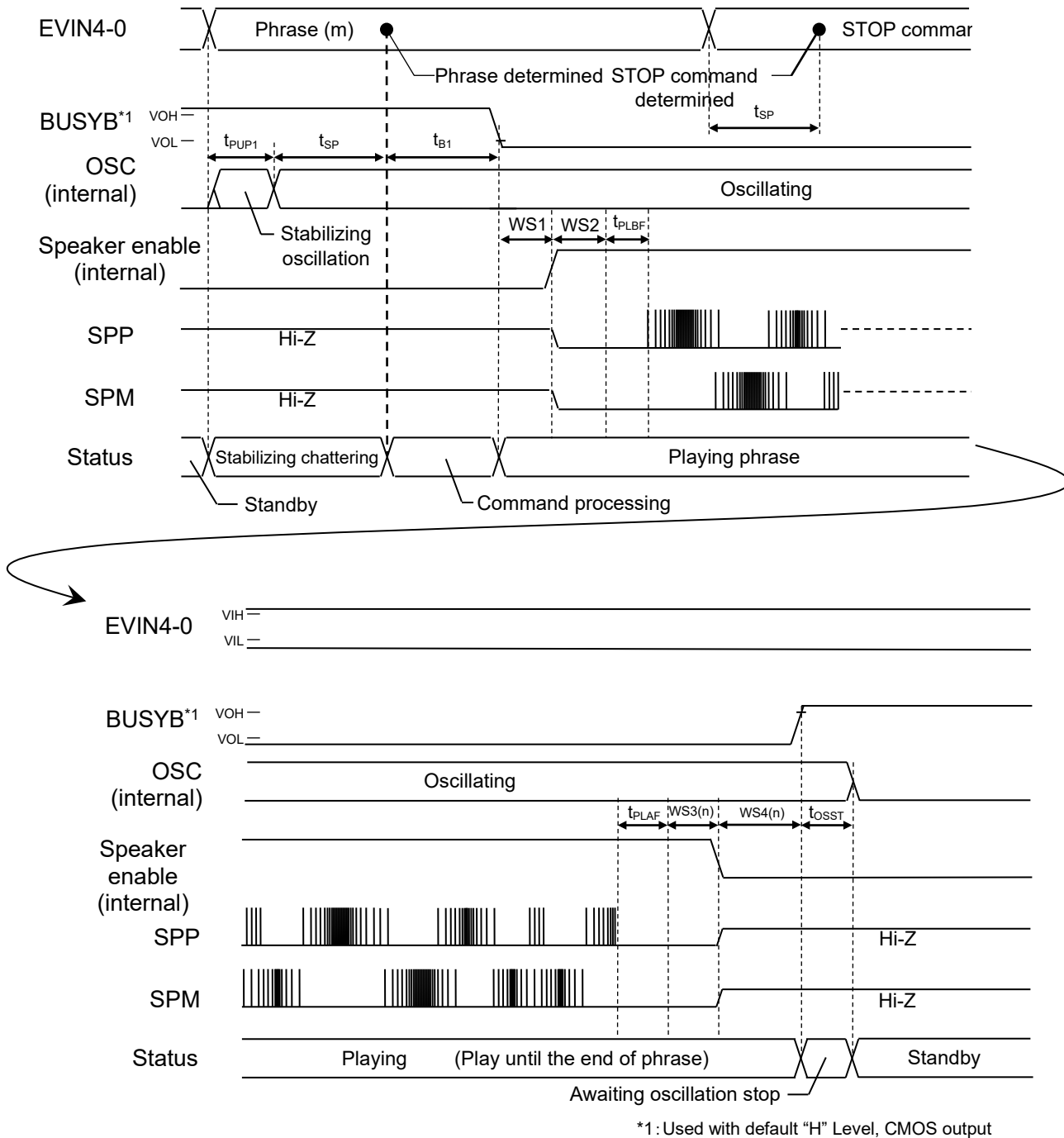

- Change Immediately Once mode and Change Immediately mode voice stop timing

After STOP command is input, the voice fades out, and the playback stops.

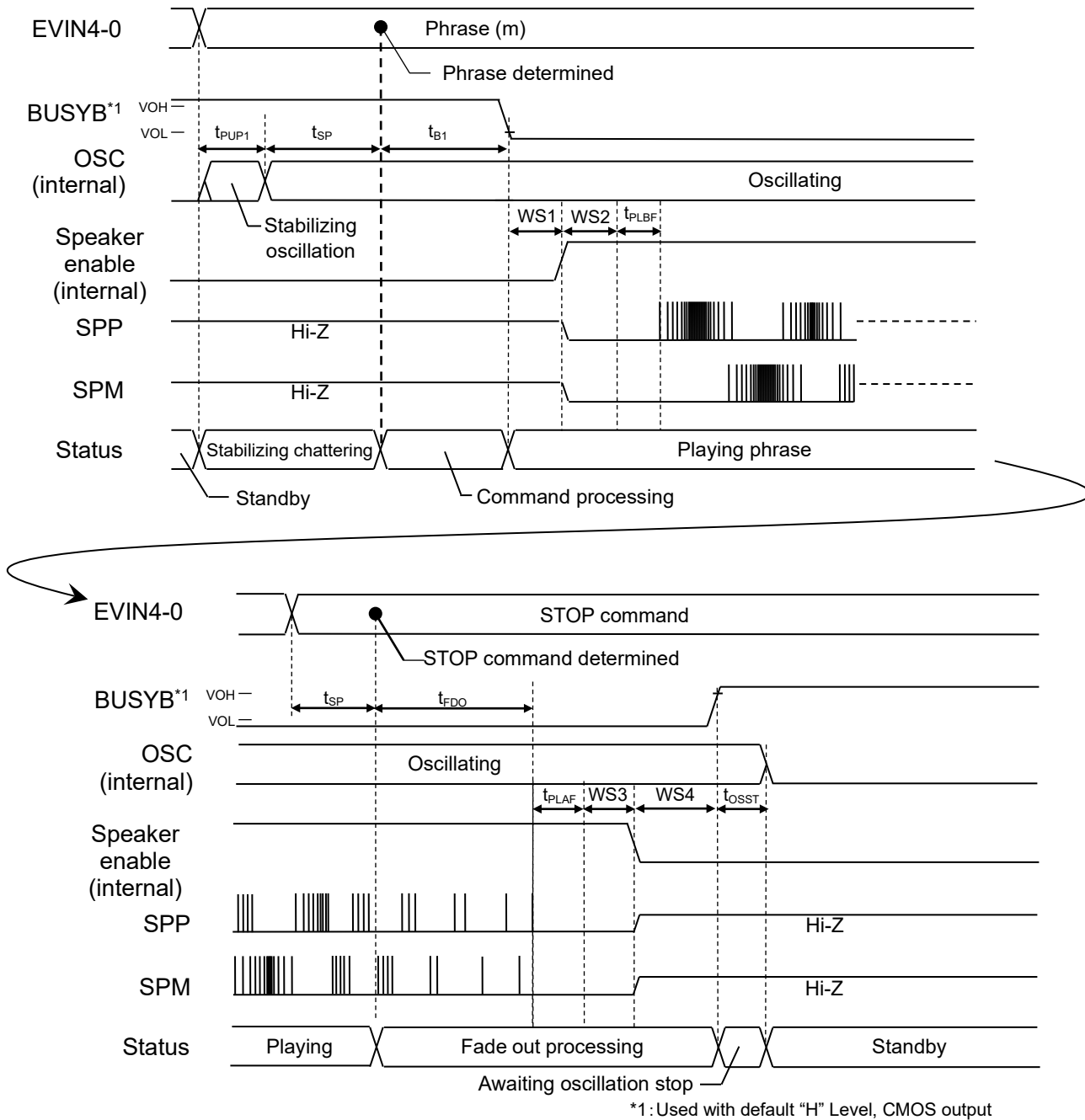

• Disconnection detection timing

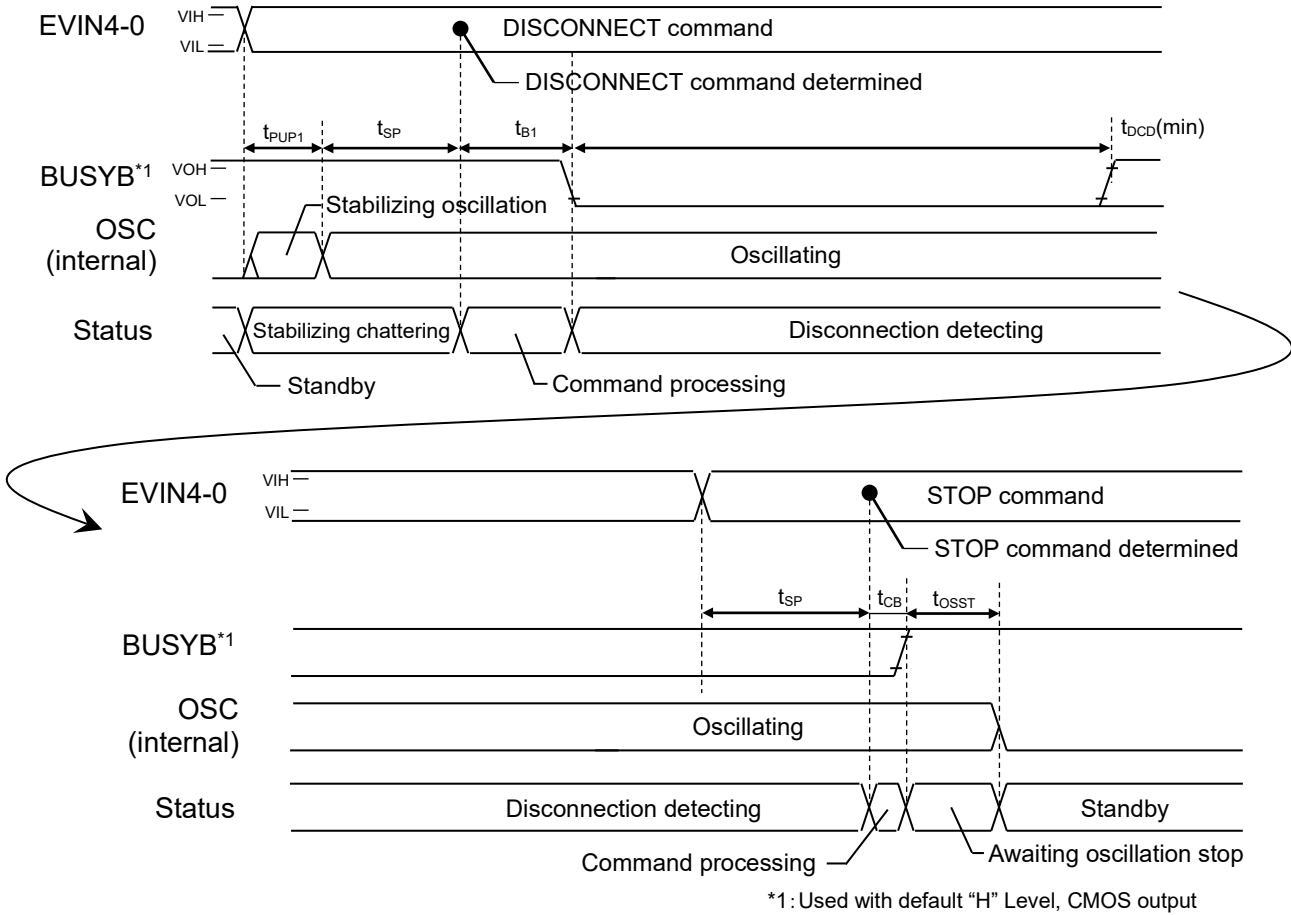

*1: Used with default "H" Level, CMOS output

• Speaker short detection timing

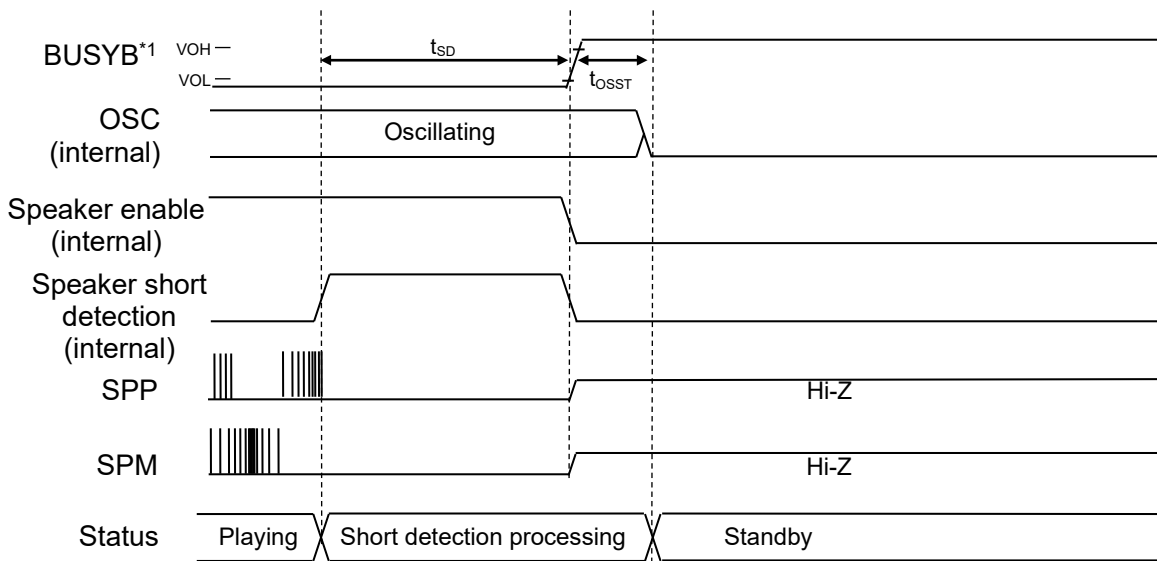

*1: Used with default "H" Level, CMOS output

■ Code Option Setting Item

Items set on Code Option Setting screen for Speech LSI Utility are as follows.

•Speaker pin short detection function setting

Use of speaker pin short detection function	<input type="checkbox"/> (Not used)
	<input type="checkbox"/> (Used)

•Command setting

Command type	<input type="radio"/> 1 byte (communicate with 1-byte command)
	<input type="radio"/> 2 byte (cannot be set)

STOP/DISCONNECT Command	Command bit sequence	
<input type="radio"/> Standard	STOP command	Use 0 0000b
	DISCONNECT command	Use 0 0001b
<input type="radio"/> Custom	STOP command	Set any bit sequence
	DISCONNECT command	Set any bit sequence (Set value different from STOP command)

•BUSYB Pins Setting

Use of BUSYB	Initial State	Condition	BUSYB pin status
<input type="checkbox"/> (Not used)	<input type="radio"/> L level Output	*	Fixed to "L" output
	<input type="radio"/> H level Output	*	Fixed to "H" output
<input type="checkbox"/> (Used)	<input type="radio"/> L level Output	<input type="radio"/> CMOS	Output initial value "L" with CMOS output
		<input type="radio"/> Nch Open Drain	Output initial value "L" with Nch open drain output
		<input type="radio"/> Pch Open Drain	Output initial value HiZ with Pch open drain output
		<input type="radio"/> Hi-Z	Hiz output
	<input type="radio"/> H level Output	<input type="radio"/> CMOS	Output initial value "H" with CMOS output
		<input type="radio"/> Nch Open Drain	Output initial value HiZ with Nch open drain output
		<input type="radio"/> Pch Open Drain	Output initial value "H" with Pch open drain output
		<input type="radio"/> Hi-Z	Hiz output

*: Setting value invalid

•EVIN4 to EVIN0 Pins Setting

EVIN4-1	<input type="radio"/> Hi-Z	Used with high impedance input
	<input type="radio"/> Pull Down	Used with pull-down input
	<input type="radio"/> Pull-up	Used with pull-up input
EVIN0	<input type="radio"/> Hi-Z	Used with high impedance input
	<input type="radio"/> Pull Down	Used with pull-down input (cannot be set)
	<input type="radio"/> Pull-up	Used with pull-up input

•Chattering removal time setting

Chattering removal time	Set chattering removal time within a range of 2 ms to 62 ms (initial value is 16 ms)
-------------------------	--

■ Event Setting Item

Items set on Event Setting screen for Speech LSI Utility are as follows.

- Playback mode
Set playback mode suitable for target playback, with reference to “Playback mode” in FUNCTIONAL DESCRIPTION.
- Volume setup
Set playback mode suitable for target playback, with reference to “Volume setup function” in FUNCTIONAL DESCRIPTION.
- Setting Wait time before and after volume playback
Set desired Wait time with reference to “Function of setting wait time before and after playback (WS1, WS2, WS3, WS4)”.

■ TERMINATION OF THE V_{DDL} PIN

The VDDL pin is the regulator output that is power supply pin for the internal logic circuits. Connect a capacitor between this pin and the ground in order to prevent noise generation and power fluctuation.

The recommended capacitance value is shown below. However, it is important to evaluate and decide using the own board.

Also, start the next operation after each output voltage is stabilized.

Pin	Recommended capacitance value	Remarks
VDDL	10 μ F \pm 20%	The larger the connection capacitance, the longer the settling time.

■ POWER SUPPLY WIRING

The power supplies of this LSI are divided into the following two:

- Power supply for logic circuitry (: DVDD)
- Power supply for speaker amplifier (: SPVDD)

The example of power connection is shown below

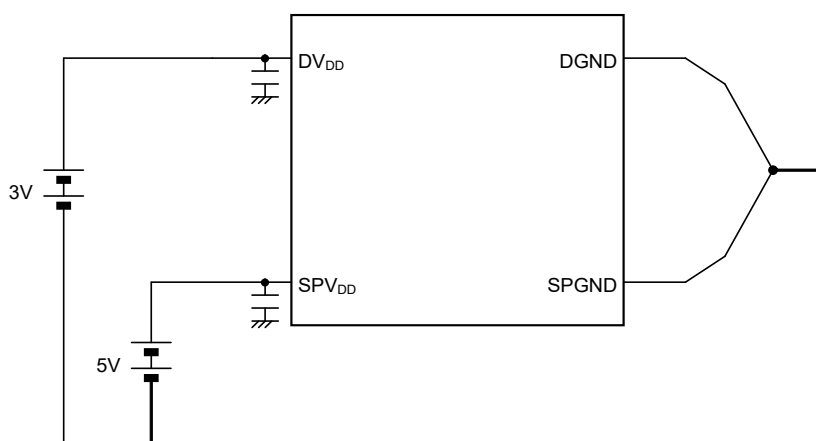
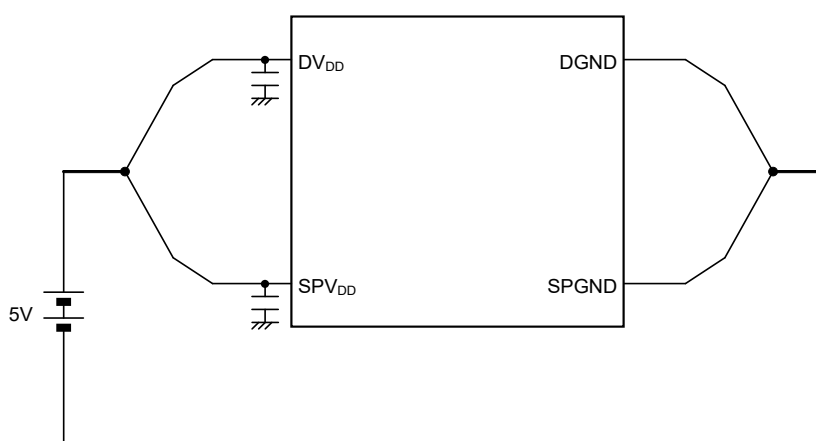

- Turn on DVDD and SPVDD simultaneously, or turn on SPVDD after turning on DVDD.
- Turn off DVDD and SPVDD simultaneously, or turn off DVDD after turning on SPVDD.

■ APPLICATION CIRCUIT

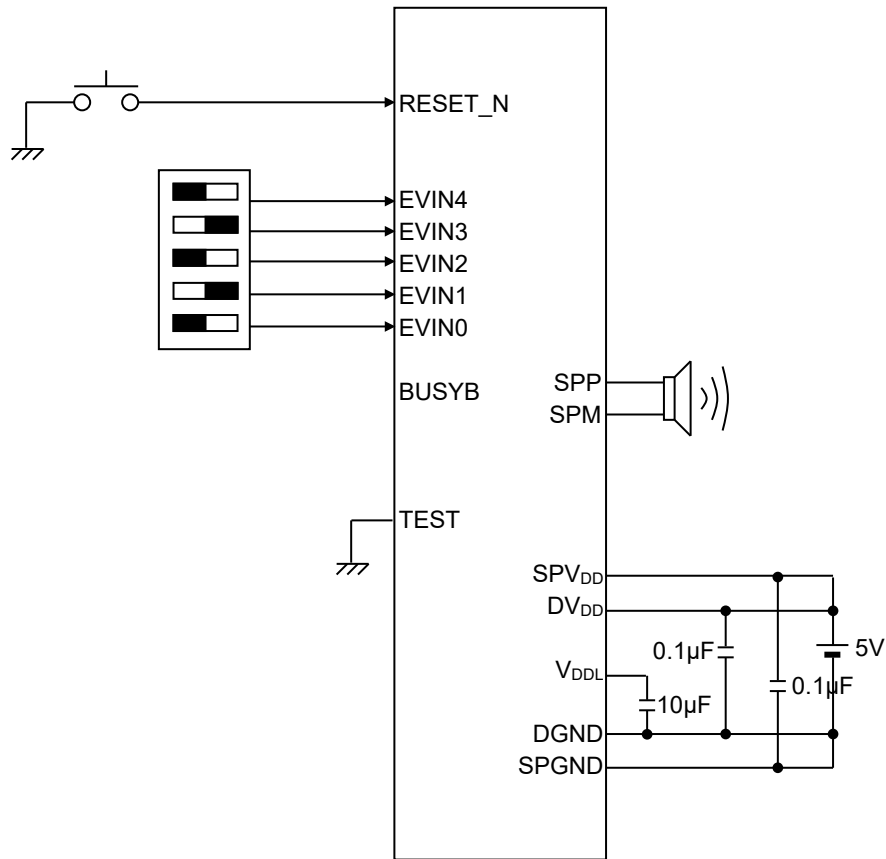

■ PACKAGE DIMENSIONS

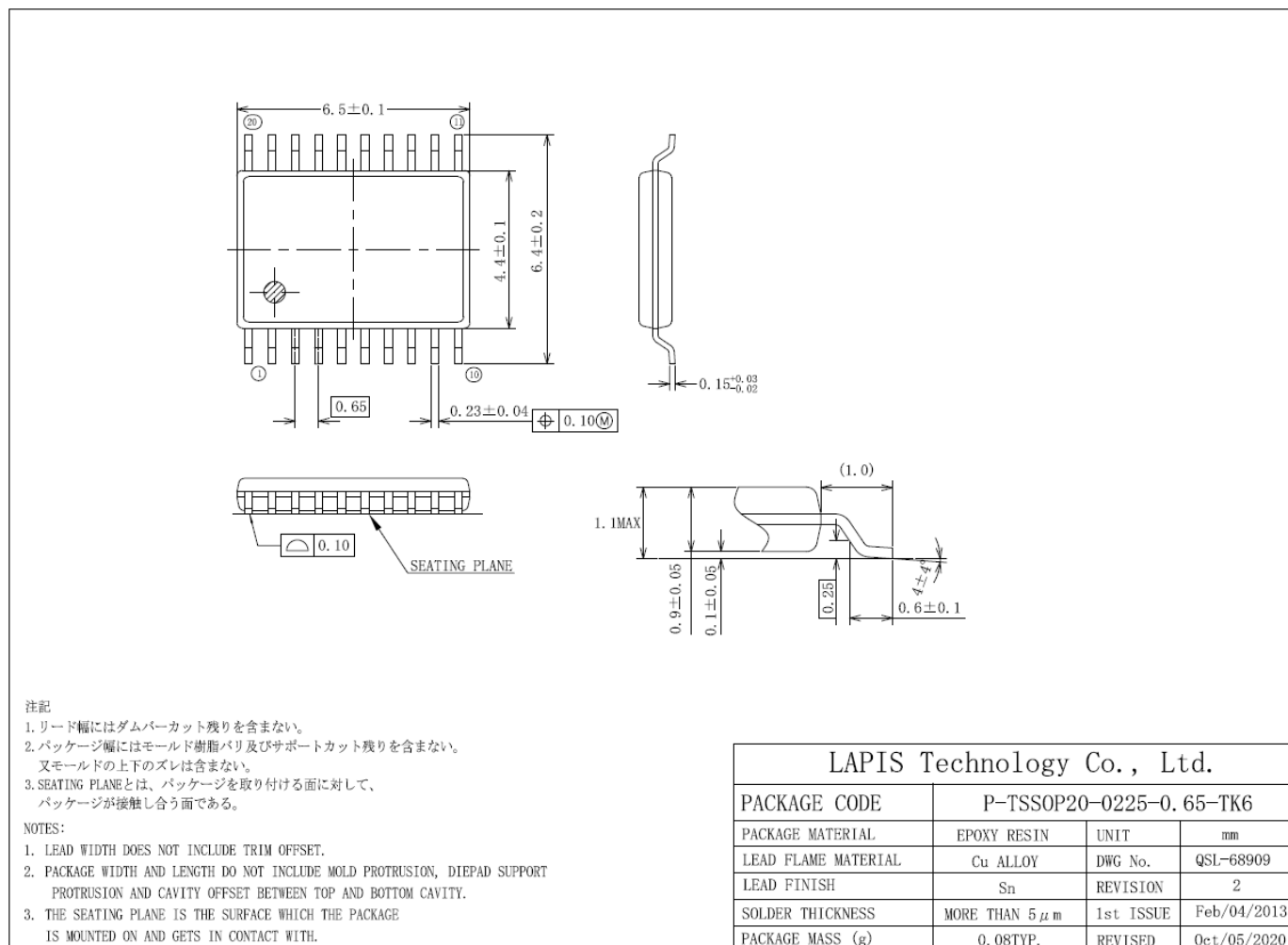

Notes for Mounting the Surface Mount Type Package

The surface mount type packages are very susceptible to heat in reflow mounting and humidity absorbed in storage. Therefore, before you perform reflow mounting, contact a ROHM sales office for the product name, package name, pin number, package code and desired mounting conditions (reflow method, temperature and times).

PCB Layer	JEDEC 4layers	JEDEC 2layers
PCB	(W/L/t= 76.2 / 114.3 / 1.6 (mm))	
Air cooling conditions	Calm(0m/sec)	
Heat resistance (θ ja)	63.7[°C /W]	69.4[°C /W]
Heat resistance (θ jc)	0.46[°C/W]	0.48[°C /W]
Maximum power consumption of LSI (PMax) At 1W into 8 Ω playback	0.28[W]	

TjMax of this LSI is 125 °C. TjMax is expressed with the following formulas.

$$TjMax = TaMax + \theta ja \times PMax$$

半田付け部端子存在範囲図

Mounting area for package lead soldering to PC boards

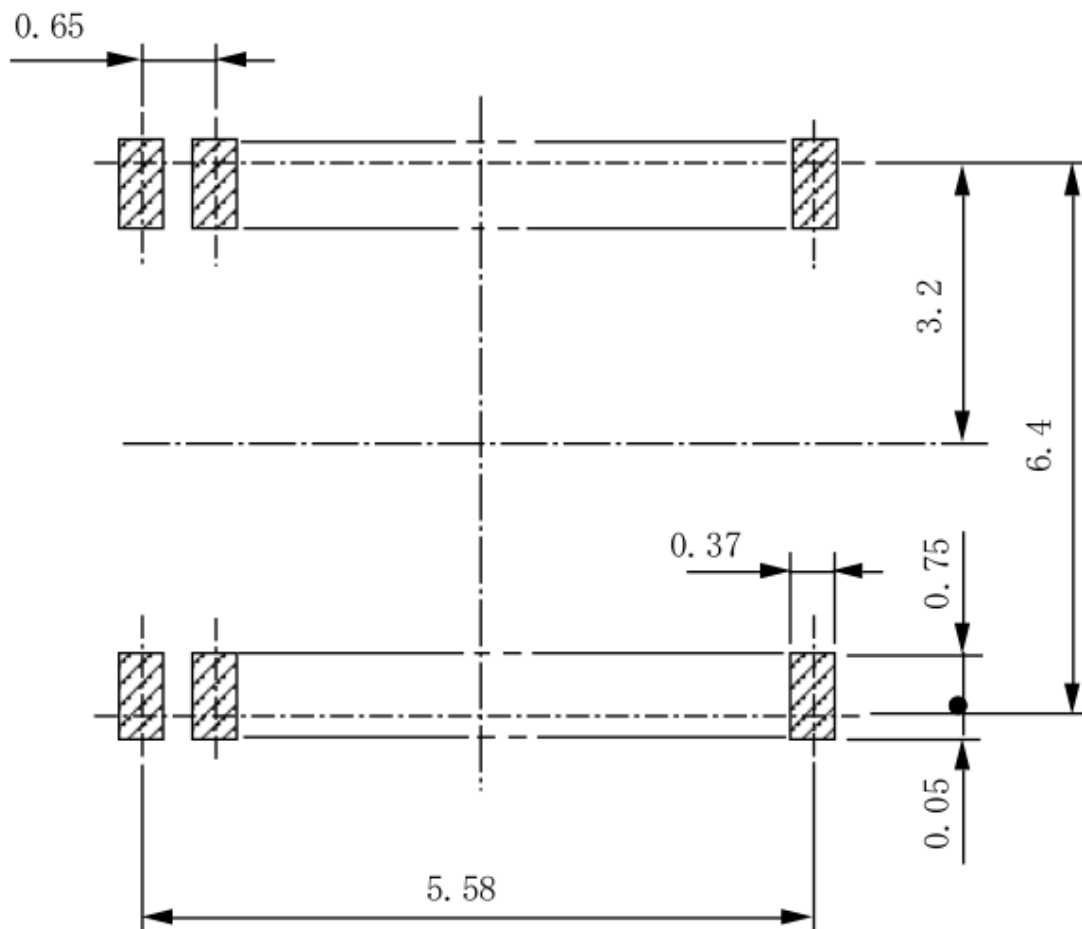

[単位/Unit:mm]

実装基板のフットパターンの設計の際には、実装の容易さ、接続の信頼性、配線の引き回し、半田ブリッジ発生のないことなどを十分考慮してください。

フットパターンの最適な設計は基板材質、使用する半田ペースト種類、厚み、半田付け方法などによって変わってきます。従って、本パッケージの端子の存在し得る範囲を「半田付け部端子存在範囲図」として示しますので、フットパターン設計の参考資料としてください。

When laying out PC boards, it is important to design the foot pattern so as to give consideration to ease of mounting, bonding, positioning of parts, reliability, wiring, and elimination of solder bridges.

The optimum design for the foot pattern varies with the materials of the substrate, the sort and thickness of used soldering paste, and the way of soldering. Therefore when laying out the foot pattern on the PC boards, refer to this figure which means the mounting area that the package leads are allowable for soldering to PC boards.

■ REVISION HISTORY

Document No	Date	Page		Description
		Previous Edition	Current Edition	
FEDL22Q284-01	Mar 5, 2021	—	—	Formal 1st edition.
FEDL22Q284-02	Mar 30, 2021	6	6	SPP, SPM terminal output short-circuit current value change. (Before change) 300mA (After change) 600mA
FEDL22Q284-03	Oct 4, 2021	15	15	Speaker short-circuit detection warning added.
		16	16	Added a note on using commands.
		17	17	Added a note on phrase playback after the STOP command.
		21	21	Added a note for phrase playback after transitioning to BUSYB "H" level.
		31	31	Describe the thermal resistance information of the package.
		-	32	Added "Mounting area for package lead soldering to PC boards".
FEDL22Q284-04	Jun 29, 2022	31	31	Removed "(SSOP16)" notation for PACKAGE DIMENSIONS.

Notes

- 1) The information contained herein is subject to change without notice.
- 2) When using LAPIS Technology Products, refer to the latest product information (data sheets, user's manuals, application notes, etc.), and ensure that usage conditions (absolute maximum ratings, recommended operating conditions, etc.) are within the ranges specified. LAPIS Technology disclaims any and all liability for any malfunctions, failure or accident arising out of or in connection with the use of LAPIS Technology Products outside of such usage conditions specified ranges, or without observing precautions. Even if it is used within such usage conditions specified ranges, semiconductors can break down and malfunction due to various factors. Therefore, in order to prevent personal injury, fire or the other damage from break down or malfunction of LAPIS Technology Products, please take safety at your own risk measures such as complying with the derating characteristics, implementing redundant and fire prevention designs, and utilizing backups and fail-safe procedures. You are responsible for evaluating the safety of the final products or systems manufactured by you.
- 3) Descriptions of circuits, software and other related information in this document are provided only to illustrate the standard operation of semiconductor products and application examples. You are fully responsible for the incorporation or any other use of the circuits, software, and information in the design of your product or system. And the peripheral conditions must be taken into account when designing circuits for mass production. LAPIS Technology disclaims any and all liability for any losses and damages incurred by you or third parties arising from the use of these circuits, software, and other related information.
- 4) No license, expressly or implied, is granted hereby under any intellectual property rights or other rights of LAPIS Technology or any third party with respect to LAPIS Technology Products or the information contained in this document (including but not limited to, the Product data, drawings, charts, programs, algorithms, and application examples, etc.). Therefore LAPIS Technology shall have no responsibility whatsoever for any dispute, concerning such rights owned by third parties, arising out of the use of such technical information.
- 5) The Products are intended for use in general electronic equipment (AV/OA devices, communication, consumer systems, gaming/entertainment sets, etc.) as well as the applications indicated in this document. For use of our Products in applications requiring a high degree of reliability (as exemplified below), please be sure to contact a LAPIS Technology representative and must obtain written agreement: transportation equipment (cars, ships, trains, etc.), primary communication equipment, traffic lights, fire/crime prevention, safety equipment, medical systems, servers, solar cells, and power transmission systems, etc. LAPIS Technology disclaims any and all liability for any losses and damages incurred by you or third parties arising by using the Product for purposes not intended by us. Do not use our Products in applications requiring extremely high reliability, such as aerospace equipment, nuclear power control systems, and submarine repeaters, etc.
- 6) The Products specified in this document are not designed to be radiation tolerant.
- 7) LAPIS Technology has used reasonable care to ensure the accuracy of the information contained in this document. However, LAPIS Technology does not warrant that such information is error-free and LAPIS Technology shall have no responsibility for any damages arising from any inaccuracy or misprint of such information.
- 8) Please use the Products in accordance with any applicable environmental laws and regulations, such as the RoHS Directive. LAPIS Technology shall have no responsibility for any damages or losses resulting non-compliance with any applicable laws or regulations.
- 9) When providing our Products and technologies contained in this document to other countries, you must abide by the procedures and provisions stipulated in all applicable export laws and regulations, including without limitation the US Export Administration Regulations and the Foreign Exchange and Foreign Trade Act..
- 10) Please contact a ROHM sales office if you have any questions regarding the information contained in this document or LAPIS Technology's Products.
- 11) This document, in part or in whole, may not be reprinted or reproduced without prior consent of LAPIS Technology.

(Note) "LAPIS Technology" as used in this document means LAPIS Technology Co., Ltd.

Copyright 2021 LAPIS Technology Co., Ltd.

LAPIS Technology Co.,Ltd.

2-4-8 Shinyokohama, Kouhoku-ku, Yokohama 222-8575, Japan
<https://www.lapis-tech.com/en/>